

Date: \_\_\_\_\_ For:  File  Resubmit  
 PO No.: \_\_\_\_\_  Approval  Other \_\_\_\_\_  
 Architect: \_\_\_\_\_ GC: \_\_\_\_\_  
 Engr: \_\_\_\_\_ Mech: \_\_\_\_\_  
 Rep: \_\_\_\_\_  
 (Company) \_\_\_\_\_ (Project Manager) \_\_\_\_\_



**LV420HV**  
 Single Zone Vertical Air Handler Unit  
 Outdoor Unit (ODU) - LUU428HV Indoor Unit (IDU) - LVN420HV

**Performance:**

**Cooling:**

Cooling (Min-Rated-Max, Btu/h)	17,000 ~ 42,000 ~ 48,000
SEER/EER	17.0/11.05

SEER - Seasonal Energy Efficiency Rating EER - Energy Efficiency Rating

**Heating:**

Heating (Min-Rated-Max, Btu/h)	18,000 ~ 47,000 ~ 55,000
HSPF	10

HSPF - Heating Seasonal Performance Factor

Cooling Nominal Test Conditions: Heating Nominal Test Conditions:  
 Indoor: 80°F DB/67°F WB Indoor: 70°F DB/60°F WB  
 Outdoor: 95°F DB/75°F WB Outdoor: 47°F DB/43°F WB

**Electrical:**

Power Supply (V/Hz/Ø)	208-230 / 60 / 1
-----------------------	------------------

**Outdoor Unit:**

MOP (A)	40
MCA (A)	32
Cooling Rated Amps (A)	24.2
Compressor (A)	21.0
Fan Motor (A)	1.6 x 2

MOP - Maximum Overcurrent Protection MCA - Minimum Circuit Ampacity

**Total Power Input:**

Cooling Power Input (Min-Rated-Max, kW)	1.35 ~ 3.80 ~ 5.30
Heating Power Input (Min-Rated-Max, kW)	1.45 ~ 4.00 ~ 5.65

**Piping:**

Liquid Line (in, OD)	3/8
Vapor Line (in, OD)	5/8
Additional Refrigerant (oz/ft)	0.43
Min/Max Pipe Length (ft) <sup>2</sup>	6.6/246
Pipe Length (no add'l Refrigerant, ft)	24.6
Max Elevation (ft)	98.4

**Features:**

- ESP control
- Auto restart
- Sleep mode
- Hot start
- Group control
- Built in dry contact
- Optional Wi-Fi
- Timer (on/off)
- Inverter (variable speed fan)

**Included Accessories:**

- Simple Controller with Mode (White) - PQRCVCLQW

**Optional Accessories:**

- Wi-Fi Module - PCRCUDT3
- LG MultiSITE™ CRC1 Controller - PREMTBVC0
- Wireless Remote Controller - PQWRHQ0FDB
- Wall Mounted Temperature Sensor - PQRSTA0
- Base Pan Heater for ODU - PQSH1200
- Low Ambient Wind Baffle (cooling operation to -4°) - ZLABGP04A<sup>10</sup>
- Electric Heater 3kW - ANEH033B1<sup>11</sup>
- Downflow Conversion Kit - PNDFK0

For continual product development, LG reserves the right to change specifications without notice.

© LG Electronics U.S.A., Inc., Englewood Cliffs, NJ. All rights reserved. "LG Life's Good" is a registered trademark of LG Corp. /www.lghev.com

**Operating Range:**

**Outdoor Unit:**

Cooling (°F DB)	5 - 118
Heating (°F WB)	-4 - 64

**Indoor Unit:**

Cooling (°F WB)	57-77
Heating (°F DB)	59-81

**Unit Data:**

Refrigerant Type/Control	R410A/EEV
Refrigerant Charge (lbs)	7.5
ODU Sound Pressure Max (Cool/Heat) ±3 dB(A) <sup>3</sup>	52/54
IDU Sound Pressure (H/M/L) ±3 dB(A) <sup>3</sup>	48/45/44
ODU Net Weight (lbs)	203
ODU Shipping Weight (lbs)	232
IDU Net Weight (lbs)	165
IDU Shipping Weight (lbs)	188

**Fan:**

ODU/IDU Fan Type	Propeller/Sirocco
Fan Speeds (Fan/Cooling/Heating)	3/3/3
Fan Quantity (ODU + IDU)	2 + 1
Motor/Drive	Brushless Digitally Controlled / Direct
ODU Air Circulation (CFM)	1,942 x 2
IDU Air Circulation H/M/L (CFM)	1,260 / 1,100 / 1,000
IDU External Static Pressure (ESP) (in-wg)	0.3
Minimum ESP/Fan Setting Value <sup>4</sup>	0.1/70
Maximum ESP/Fan Setting Value <sup>4</sup>	0.5/96
Dehumidification Rate (pts/hr)	4.3

**Notes:**

1. Acceptable operating voltage: 187V - 253V.
2. Piping lengths are equivalent.
3. Sound Pressure levels are tested in an anechoic chamber under ISO Standard 3745.
4. Fan setting value correlates to High speed air flow.
5. All power/communication cable to be minimum 18 American wire gage (AWG), 4-conductor, stranded, shielded or unshielded wire and must comply with applicable local and national code. If shielded, the wire must be grounded to the chassis at the outdoor unit only.
6. Power wiring cable size must comply with the applicable local and national code.
7. The indoor unit comes with a dry helium charge.
8. This data is rated 0 ft above sea level, with 25 ft of refrigerant line and a 0 ft level difference between outdoor and indoor units.
9. Must follow installation instructions in the applicable LG installation manual.
10. If the optional low ambient wind baffle (ZLABGP04A) is used, one wind baffle is required for each ODU fan.
11. Electric heater accessory available in 3kW, 5kW, 8kW, 10kW, 15kW, and 20kW capacities. Refer to the engineering manual for details.



**LUU428HV**  
Single Zone Vertical Air Handler Unit



Tag #: \_\_\_\_\_

Date: \_\_\_\_\_

PO No.: \_\_\_\_\_

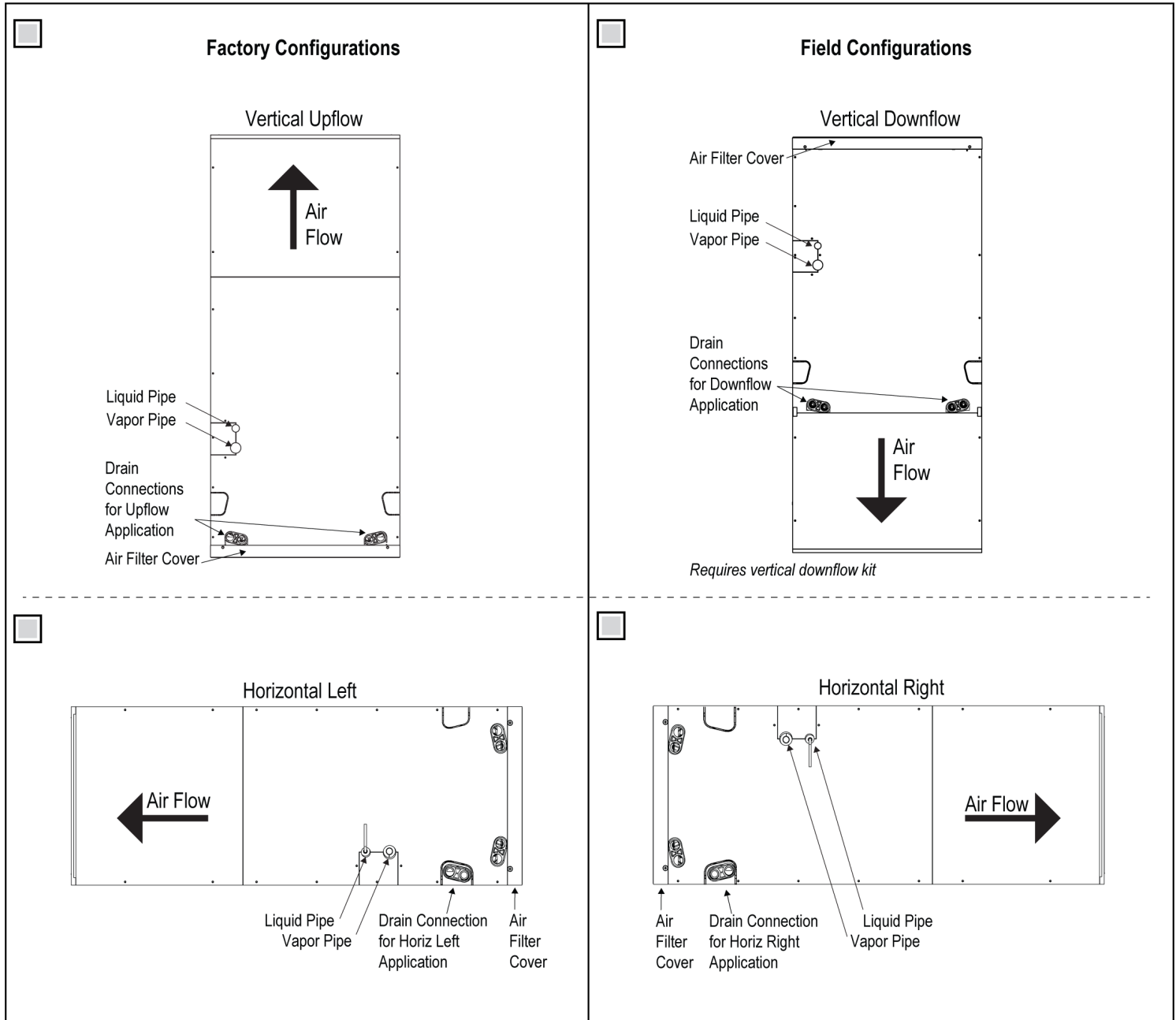

**LUU428HV**  
Single Zone Vertical Air Handler Unit



Tag #: \_\_\_\_\_  
Date: \_\_\_\_\_  
PO No.: \_\_\_\_\_

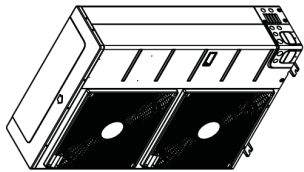

3D View

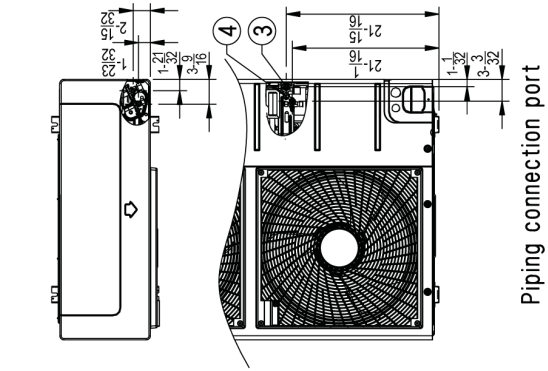
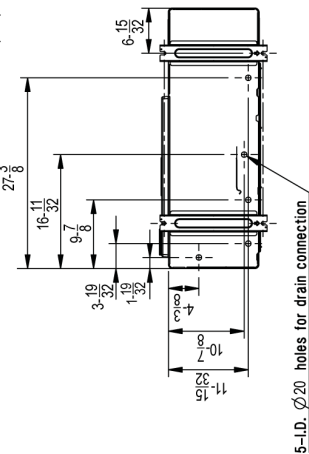
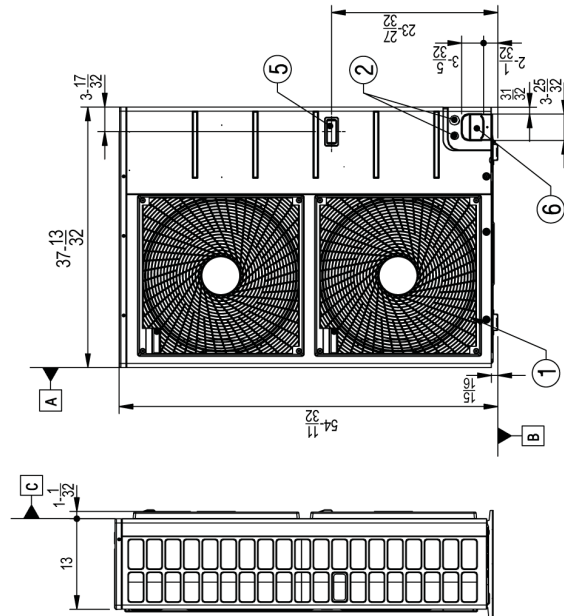
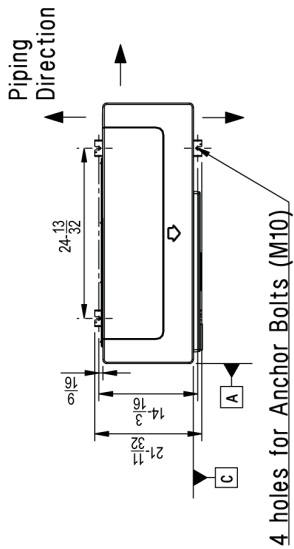

No.	Part Name	Description
8	Pipe routing hole (back)	-
7	Pipe routing hole (side)	-
6	Pipe routing hole (front)	-
5	Handle	-
4	Liquid Pipe Connection	Flare joint
3	Gas Pipe Connection	Flare joint
2	Power and communication cable Hole	-
1	Air Outlet	-

**Symbols**

- Piping Direction
- ▲ Datum line

[Unit: inch]

**LVN420HV**  
**Single Zone Vertical Air Handler Unit**



Tag #: \_\_\_\_\_

Date: \_\_\_\_\_

PO No.: \_\_\_\_\_

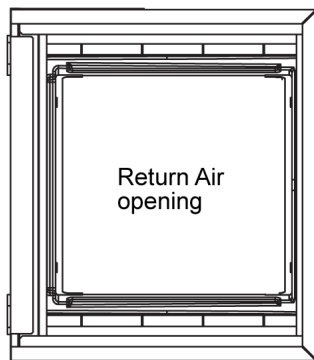
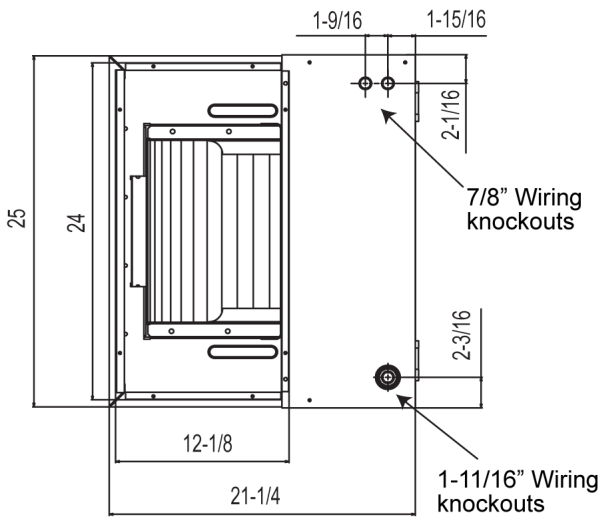
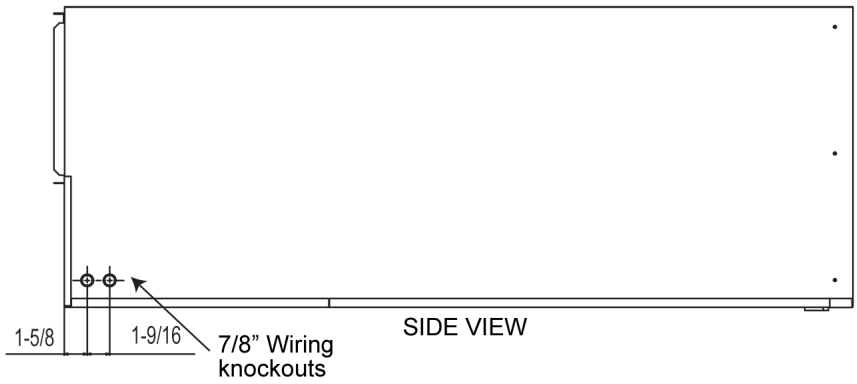
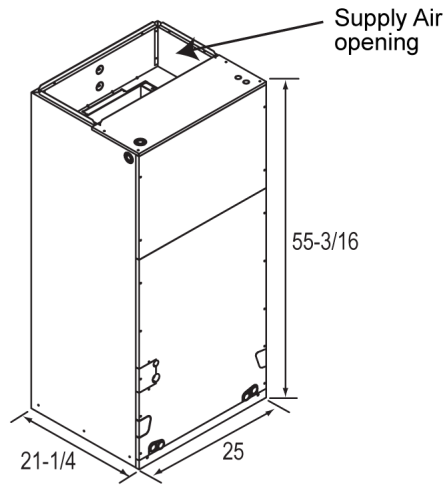

Unit: inches

Note: All measurements have a tolerance of  $\pm 1/4$  in.

