



SR TRACE®

Roof & Gutter De-icing Self-Regulating Heating Cable Application/Specification Guide

READ CAREFULLY

DESCRIPTION

Easy Heat SR Trace SR51J and SR52J heater cables provide a solution for ice dams that can build up and damage buildings and gutters. SR Trace is a self-regulating heating cable that automatically varies its heat output with changes in surrounding temperature. Because of this, SR Trace can be overlapped without fear of overheating. Consult roofing materials supplier for compatibility details.

The SR Trace roof & gutter deicing cable is available with an average density of 8 watts per foot when deicing; 5 watts per foot at 50°F. At other temperatures, of course, the cable output will be considerably different.

CONSTRUCTION DETAILS

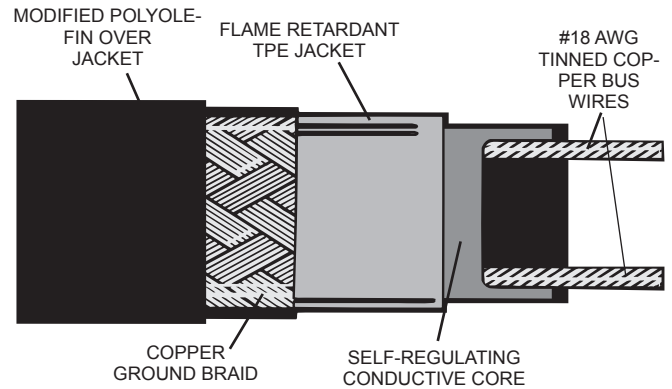

PRINCIPLE OF OPERATION

As snow accumulates on a roof in winter, inadequate ceiling insulation and/or roof venting can allow the roof surface above heated areas of the building to get warm enough to melt some of the snow on the roof surface, even on cold winter days.

This water will then flow down the roof and may accumulate and freeze in gutters, possibly even overflowing them and forming long icicles.

(Icicles are usually a symptom of this “warm roof” problem. It can be expected that roofs with icicles will eventually form ice dams which may result in water leaking into the building.)

Left unchecked, this ice build-up (icing) can result in significant stress on the gutter, often leading to mechanical failure of the gutter.

It is also probable that the roof area above the overhang will be cold, since it is not above a heated area of the building. This can result in the re-freezing of the melt-water, as it approaches the roof edge, forming a layer of ice.

Continued freezing of this water causes the layer of ice to build up in thickness and eventually can become several inches thick. This results in water “ponding”, at the warm/cold transition point of the roof, and seeping between the shingles.

Once water gets under the shingles, it can leak through the roof sheathing, at nail holes or other roof penetrations,

and down inside the building walls, ceiling, etc. It is also possible for such water to track along ceiling beams and eventually leak into the building interior at light fixtures or through the ceiling finish at a point some distance away from the location of the ice dam.

By applying heating cable on the roof edge above the overhang, and in the gutter and downspouts, water melting on the roof will always have a clear path to the ground.

Nominal Power Output

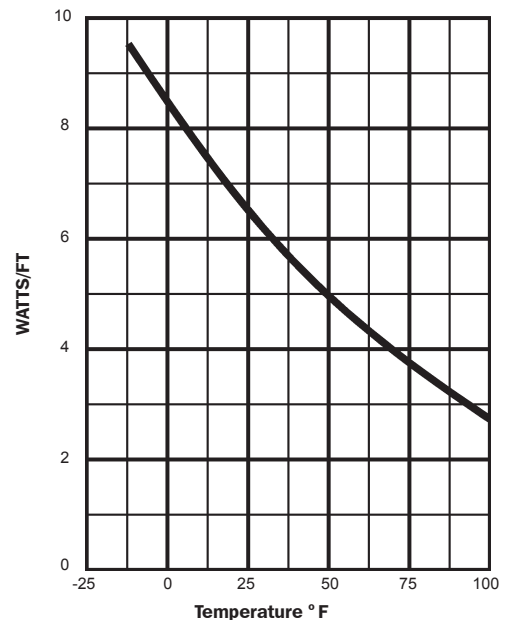

USA	Canada
2 Connecticut South Drive East Granby CT 06026	99 Union Street Elmira ON N3B 3L7
TEL 800/537-4732	TEL 519/669-2444
FAX 860/653-4938	FAX 519/669-6419

www.easyheat.com

PERFORMANCE INFORMATION

Performance and Rating Data

Catalog Number	SR51J	SR52J
Voltage (VAC)	120	208 240 277
Nominal Power Output in Ice (W/ft)	8.0	8.0
Nominal Power Output @ 50°F	5.0	5.0
Maximum Single Cable Length (ft)	142	381
Minimum Installation Temp (°F)	-40°F	-40°F
Minimum Installation Temp (°C)	-40°C	-40°C
Current Load (Amp/ft)		
at 0°F (-20°C) start-up	.132	.066
at -20°F (-30°C) start-up	.147	.074

Maximum single heater length (ft) / Circuit breaker size
0°F (-20°C)/-20°F(-30°C) start-up (length in feet)

Catalog Number	SR51J	SR52J
15 Amp Breaker	125/115/100	250/225/205
20 Amp Breaker	170/150/135	335/300/270
30 Amp Breaker	250/225/205	500/455/405

Maximum total heater length (ft) / Circuit breaker size
20°F (-7°C)/0°F (-20°C)/-20°F(-30°C) start-up

The use of ground fault protection equipment for heating cable applications is required by NEC and

STEP 1. DETERMINE CABLE LENGTH

Table 1 Cable Length Requirements Summary

Item	Cable Length Required (ft)	Comment
Roof Edge	From Table at right	Select from cable length required
Dormer Perimeter	1' per foot	1 foot of cable/foot of dormer perimeter
Roof Valley Gutter	6' minimum 1' per ft	Per valley (3 ft. loop) 1 Trace/6" of gutter width
Downspout	2' per ft	Cable is looped down and back

Table 3 Cable Length Calculation Chart

1 Roof	_____	x	_____	=	_____
	Length		Multiplier		
2 Dormers	_____	x	_____	=	_____
	Number of		up, over & down		
3 Valleys	_____	x	6'	=	_____
	Number of		3' up & 3' down		
4 Gutters	_____	x	1'	=	_____
	Length		1' cable/1' gutter		
5 Downspouts	_____	x	_____	=	_____
	Number of		2x height, up & down		
Total Cable Length =					_____
					Sum of 1 - 5

Table 2 Cable Length Factors vs. Roof Overhang

Eave Overhang "O"	Loop Height "H"= "O"+6	Length Factor Shingle Roof (Note 1)	Length Factor Metal Roof (Note 2)
12"	18"	1.9	2.5
24"	30"	2.7	3.7
36"	42"	3.6	4.5
48"	54"	4.6	5.7

Cable length required = Length Factor x roof Length (Note 3)

NOTES:

- Standard shingle roof (see diagram).
 - Metal roof with two foot loop spacing (see diagram).
 - Cable length calculated above does not include cable for gutter or downspout.
- For other designs, contact representative.

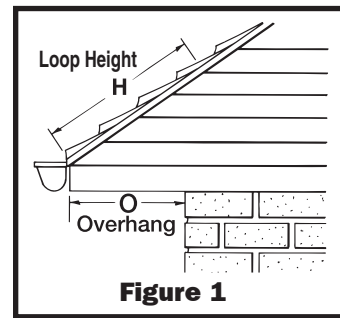

- Measure the roof length and enter it in "1" in the Cable Length Calculation Chart, Table 3.
- Measure the overhang (shown in Figure 1) and determine the length multiplier for the type of roof, Table 2. Note: If the exact overhang is not listed, use the next larger size available in the chart.
- Enter the number of dormers and the length of cable required to go up, over and down in "2" of Table 3.
- Count the number of valleys and enter that number in "3" of Table 3.
- Measure the length of the gutters and enter that length in "4" of Table 3. Note: this length will usually be the same as the roof length.
- Count the number of downspouts and enter that in the first blank of "5" of Table 3.

- Measure the height of the downspouts. Multiply that number by 2 for the length of the cable required to go down into downspout and back up to the gutter. Enter that number in the second blank of "5" of Table 3.
- Determine the amount of cable needed for each type of roof feature by multiplying the two numbers on each line together and enter those numbers on the chart.
- Sum the amount of cable needed for each type of roof feature to determine the total cable length. If this length exceeds the maximum circuit length of the cable, multiple runs will be needed. Although Easy Heat SR cable is cut to length, the amount of cable needed can be lengthened or shortened by increasing or decreasing the loop height.



USA
2 Connecticut South Drive
East Granby CT 06026
TEL 800/537-4732
FAX 860/653-4938

Canada
99 Union Street
Elmira ON N3B 3L7
TEL 519/669-2444
FAX 519/669-6419

TYPICAL SHINGLE ROOF (Single cable shown for roof and gutter)

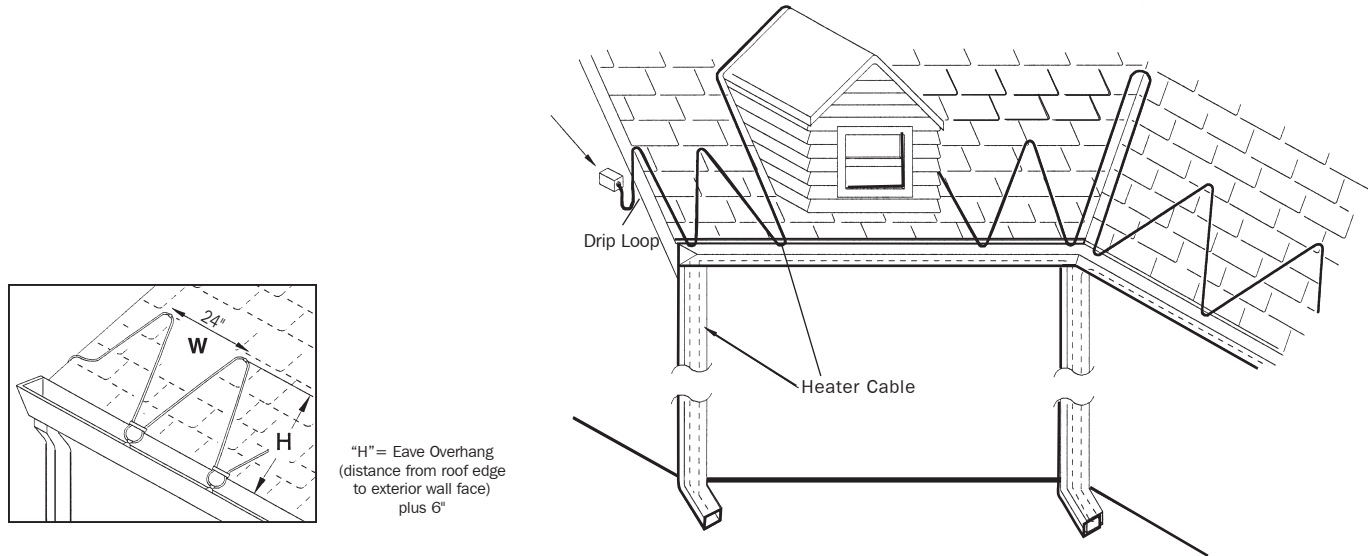

TYPICAL METAL ROOF (Separate cables shown for roof and gutter)

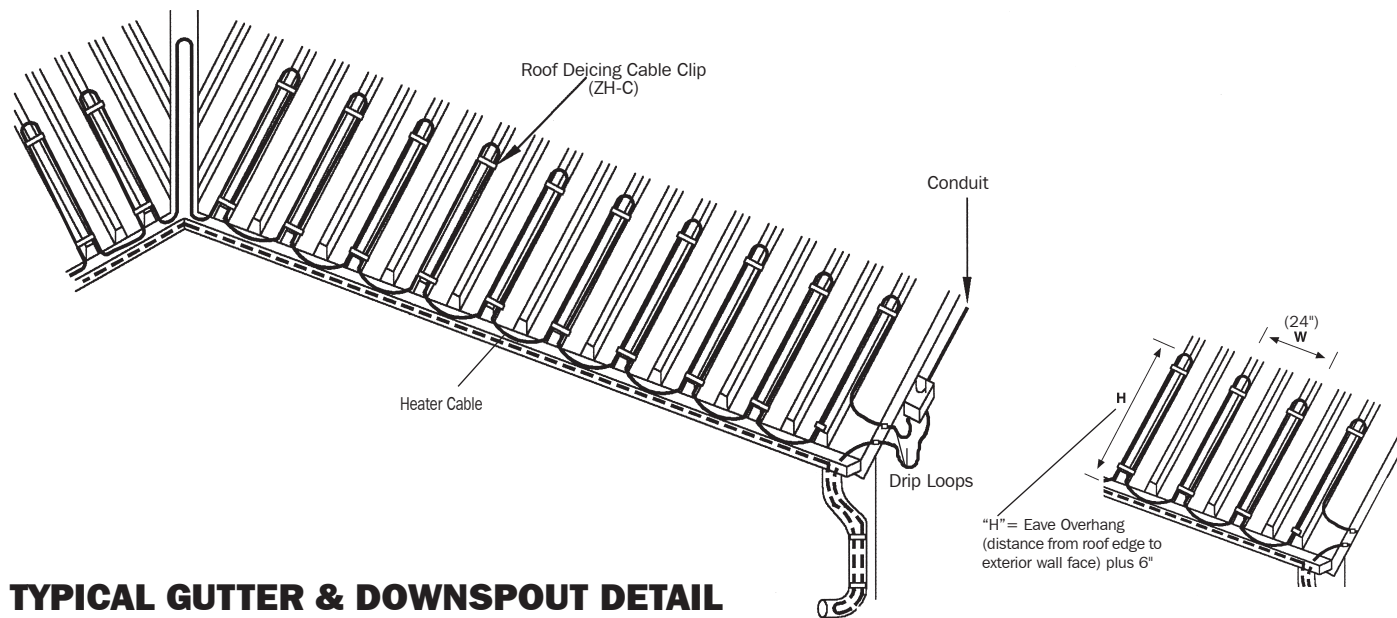

TYPICAL GUTTER & DOWNSPOUT DETAIL

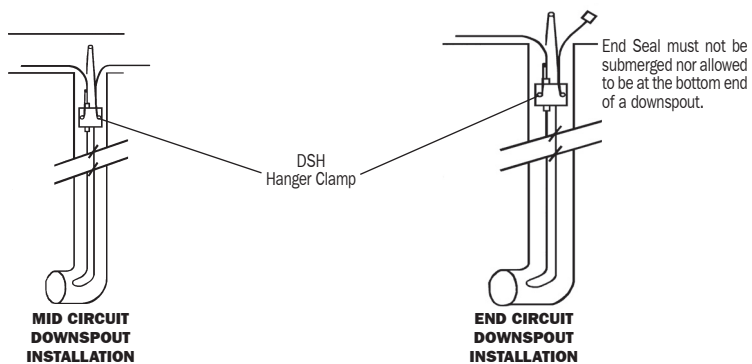
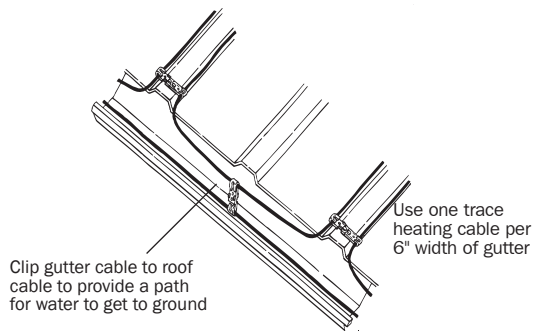

USA
 2 Connecticut South Drive
 East Granby CT 06026
 TEL 800/537-4732
 FAX 860/653-4938

Canada
 99 Union Street
 Elmira ON N3B 3L7
 TEL 519/669-2444
 FAX 519/669-6419

www.easyheat.com

STEP 2. POWER SUPPLY REQUIREMENTS

The nature of self regulating cable is that it consumes less power as it gets warmer. This is a major advantage of this type of cable, as it applies more heat to colder areas (where it is needed) than to warmer areas (where it is not needed). However, this same phenomenon also results in the cable drawing more current when power is first applied (when cable is cold), and this requires careful selection of breaker sizing to ensure cold start-ups don't trip the breaker. Hence, the total length of heater cable connected to a breaker must be limited to ensure the selected breaker does not trip on cold start-ups.

The total length of heating cable installed on any circuit must not

STEP 3. CABLE ROUTING

Due to the parallel design of this cable, power is carried down the cable by bus wires. Since current is flowing through these bus wires, there will be some voltage drop along the bus wires. It is important to limit this voltage drop to ensure that the power dissipated by the cable does not fall below that required to keep the melt-path from freezing. Hence, the total length of cable in a single run must be limited to ensure that the power dissipation at the tail end of the cable is adequate.

From the roof design, determine the length of the longest single run of

STEP 4. CABLE CONTROL

It is recommended that heating cables for roof & gutter deicing be controlled in order to minimize energy consumption. This control could be as simple as a toggle switch with a pilot light or as sophis-

exceed the "Maximum Total Length" associated with the circuit breaker supplying the circuit. If total length of heater cable required does exceed that allowed for the circuit breaker supplying the circuit, either a larger circuit breaker (and associated wiring) must be used, or multiple circuit breakers (and associated wiring) must be installed.

From the Circuit Breaker Selection table, determine the number of circuits and circuit breaker size required to supply the heating cables.

STEP 5. CABLE CONNECTION

Easy Heat offers a complete line of accessory connection kits for easy installation. Using these kits, the following connections are possible:

- SRP** CSA Certified Power Connection Kit. Provides materials necessary to perform a watertight power connection into a customer supplied ½" NPT knockout junction box. Also provides heat-shrinkable moisture proof end seal for the heating cable circuit. One SRP is required per cable to J-box connection.
- DSH** Downspout Hanger. Used to support heating cable where it enters and exits a downspout. Each kit contains two hangers.

cable. If this value exceeds the "Maximum Single Run Length" in the "Performance and Rating Data" table, then the cable routing, or type of cable selected, must be altered. For example, it may be possible to change the location of the power supply; if a 200 ft roof is being protected, the power supply location could be placed in the center of the roof length, thereby resulting in two runs of 100 ft each, instead of one run of 200 ft (maximum single run length of 200 ft). Also, 240 Volt cables allow longer single runs than 120 Volt cables.

titated as a full automatic system from Easy Heat. Automatic control options are available.

- SRES** UL Listed and CSA Certified End Seal Kit. Provides materials necessary to perform a moisture proof end seal of the heating cable circuit. Each kit contains 5 end seals.
- SRSRG** UL Listed and CSA Certified Roof and Gutter In-line Splice Kit. Provides materials necessary to perform a splice of two roof and gutter heating cables. Each kit contains one splice.
- ZH-C** Roof Clips and Spacers. Used to attach heating cable to roof and also to maintain cable spacing in gutters and downspouts. Each kit has 50 roof clips or 25 cable spacers.

LIMITED WARRANTY AND LIABILITY

Easy Heat warrants that if there are any defects in material or workmanship in any heating cable or accessory during the first year after the date of purchase. We will provide new products to replace any defective items, or we will refund the purchase price paid for the accessory or cable, not including any labor or other installation costs. As an alternate, we may elect to repair the cable or accessory at our factory with all shipping and other removal costs borne by the purchaser.

We further warrant that any services performed for the Buyer hereunder will be performed in a good and skillful manner, based on our understanding of pertinent technical data as of the date of performance of such services. Easy Heat's sole responsibility and liability in the event of any defect, error, omission, or failure in the services rendered hereunder shall be to provide corrected services of the type provided for herein, designed to correct such defect, error, omissions, or failure, and in no event shall the Easy Heat's liability with respect to such warranty exceed the amount received by it from the Buyer on account of such services.

Our obligation to provide corrected services, new products, refund the purchase price, or perform the repair described above is conditioned upon (a) the installation of the accessory or cable conforming to the specifications set forth in our installation instructions and (b) the accessory or cable not having been damaged by mechanical or electrical activities unrelated to the operation of the accessory or cable.

A refund of your purchase price, provision of replacement products, repair of the accessory or cable or provision of corrected services as described above, shall be your sole and exclusive remedy for a breach of this warranty. THESE ARE THE SOLE AND EXCLUSIVE WARRANTIES GIVEN BY EASY HEAT WITH RESPECT TO THE GOODS AND SERVICES AND ARE IN LIEU OF AND EXCLUDE ALL OTHER WARRANTIES, EXPRESS OR IMPLIED, ARISING BY OPERATION OF LAW OR OTHERWISE, INCLUDING WITHOUT LIMITATION, MERCHANTABILITY AND FITNESS FOR A PARTICULAR PURPOSE WHETHER OR NOT THE PURPOSE OR USE HAS BEEN DISCLOSED TO EASY HEAT IN SPECIFICATIONS, DRAWINGS OR OTHERWISE, AND WHETHER OR NOT EASY HEAT'S PRODUCTS ARE SPECIFICALLY DESIGNED AND/OR MANUFACTURED BY EASY HEAT FOR YOUR USE OR PURPOSE.

This warranty does not extend to any losses or damages due to misuse, accident, abuse, neglect, normal wear and tear, negligence, unauthorized modification or alteration, use beyond rate capacity, or improper installation, maintenance or application. To the extent that you or your agents have supplied specifications, information, representation of operating conditions or other data to Easy Heat in the selection or design of the Goods and the preparation of Easy Heat's quotation, and in the event that actual operating conditions or other conditions differ from those represented by you, any warranties or other provisions contained herein which are affected by such conditions shall be null and void.

If within thirty (30) days after your discovery of any warranty defects within the warranty period, you notify Easy Heat thereof in writing, Easy Heat shall, at its option, repair, correct or replace F.O.B. point of manufacture, or refund the purchase price for, that portion of the Goods found by Easy Heat to be defective. Failure by you to give such written notice within the applicable time period shall be deemed an absolute and unconditional waiver of your claim for such defects. Goods repaired or replaced during the warranty period shall be covered by the foregoing warranty for the remainder of the original warranty period or ninety (90) days from the date of shipment of the repaired or replaced goods, whichever is longer.

This limited warranty does not cover any costs relating to the repair or replacement of any accessory or cable at the installation site. Our accessories and cables are not easily accessible. A failed accessory or cable usually cannot be easily repaired. Replacement of a failed accessory or cable will require that the materials under which it is installed be removed to permit replacement of the accessory or cable. **We will not reimburse any costs relating to the repair or replacement of any accessory or cable at the installation site.**

IN NO EVENT, REGARDLESS OF THE FORM OF THE CLAIM OR CAUSE OF ACTION (WHETHER BASED IN CONTRACT, INFRINGEMENT, NEGLIGENCE, STRICT LIABILITY, OTHER TORT OR OTHERWISE), SHALL EASY HEAT'S LIABILITY TO YOU AND/OR YOUR CUSTOMERS EXCEED THE PRICE PAID BY YOU FOR THE SPECIFIC GOODS PROVIDED BY EASY HEAT GIVING RISE TO THE CLAIM OR CAUSE OF ACTION. YOU AGREE THAT WE SHALL NOT BE LIABLE TO YOU OR YOUR CUSTOMERS FOR ANY INCIDENTAL, SPECIAL OR CONSEQUENTIAL OR PUNITIVE DAMAGES. No agent, employee or representative of ours has authority to bind us to any affirmation, representation or warranty concerning the goods sold unless such affirmation, representation or warranty is specifically incorporated by written agreement.

To obtain new products, arrange repair of existing product, or a refund under this warranty, please contact Easy Heat with a description of the defect and proof of purchase at the address noted herein.



USA	Canada
2 Connecticut South Drive East Granby CT 06026	99 Union Street Elmira ON N3B 3L7
TEL 800/537-4732	TEL 519/669-2444
FAX 860/653-4938	FAX 519/669-6419

www.easyheat.com