



SINGLE ZONE EXTENDED PIPING WALL MOUNTED ENGINEERING MANUAL

2 Tons
LS243HLV3



2-1/2 and 2-3/4 Tons
LS303HLV3, LS363HLV3

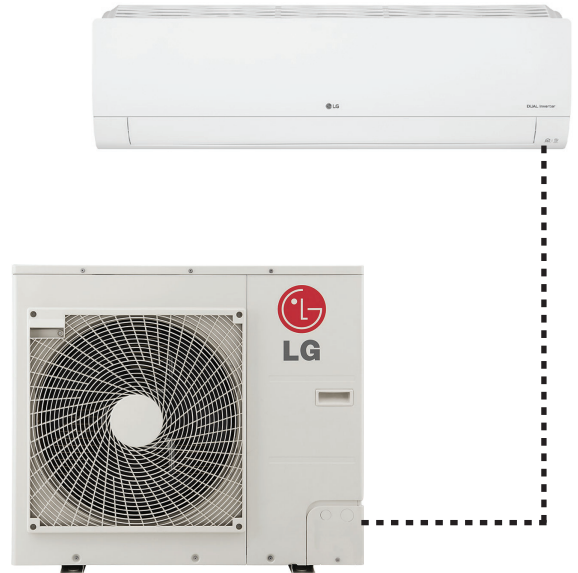

PROPRIETARY DATA NOTICE

**This document, as well as all reports, illustrations, data, information, and other materials are the property of LG Electronics U.S.A., Inc., and are disclosed by LG Electronics U.S.A., Inc. only in confidence.
This document is for design purposes only.**





A summary list of safety precautions is on page 3.

For more technical materials such as submittals, catalogs, installation, owner's, and service manuals, visit www.lghvac.com.

TABLE OF CONTENTS

Unit Nomenclature	4
LG Air Conditioner Technical Solution (LATS)	5-6
Product Data	7-35
<i>Mechanical Specifications</i>	8
<i>General Data</i>	9-10
<i>Electrical Data</i>	11
<i>Functions, Controls, Options</i>	12
<i>Outdoor Unit Dimensions</i>	13-14
<i>Indoor Unit Dimensions</i>	15-16
<i>Acoustic Data</i>	17-20
<i>Refrigerant Flow Diagram</i>	21
<i>Indoor Unit Wiring Diagram</i>	22
<i>Outdoor Unit Wiring Diagram</i>	23
<i>Electrical Connections</i>	24-27
<i>Air Flow, Static Pressure, and Temperature Distribution</i>	28-33
Performance Data	34-44
<i>Cooling Capacity</i>	35-36
<i>Maximum Cooling Capacity</i>	37-38
<i>Heating Capacity</i>	39-40
<i>Maximum Heating Capacity</i>	41-42
<i>Equipment Selection Procedure</i>	43-44
Application Guidelines	45-54
<i>Placement Considerations</i>	46-50
<i>Installing Outdoor Units Indoors</i>	51-53
<i>Refrigerant Piping Design</i>	54

TABLE OF SYMBOLS

 DANGER	<i>This symbol indicates an imminently hazardous situation which, if not avoided, will result in death or serious injury.</i>
 WARNING	<i>This symbol indicates a potentially hazardous situation which, if not avoided, could result in death or serious injury.</i>
 CAUTION	<i>This symbol indicates a potentially hazardous situation which, if not avoided, will result in minor or moderate injury.</i>
Note:	<i>This symbol indicates situations that will result in equipment or property damage accidents only.</i>
	<i>This symbol indicates an action that should not be performed.</i>

UNIT NOMENCLATURE

Single Zone Wall Mount Indoor and Outdoor Units

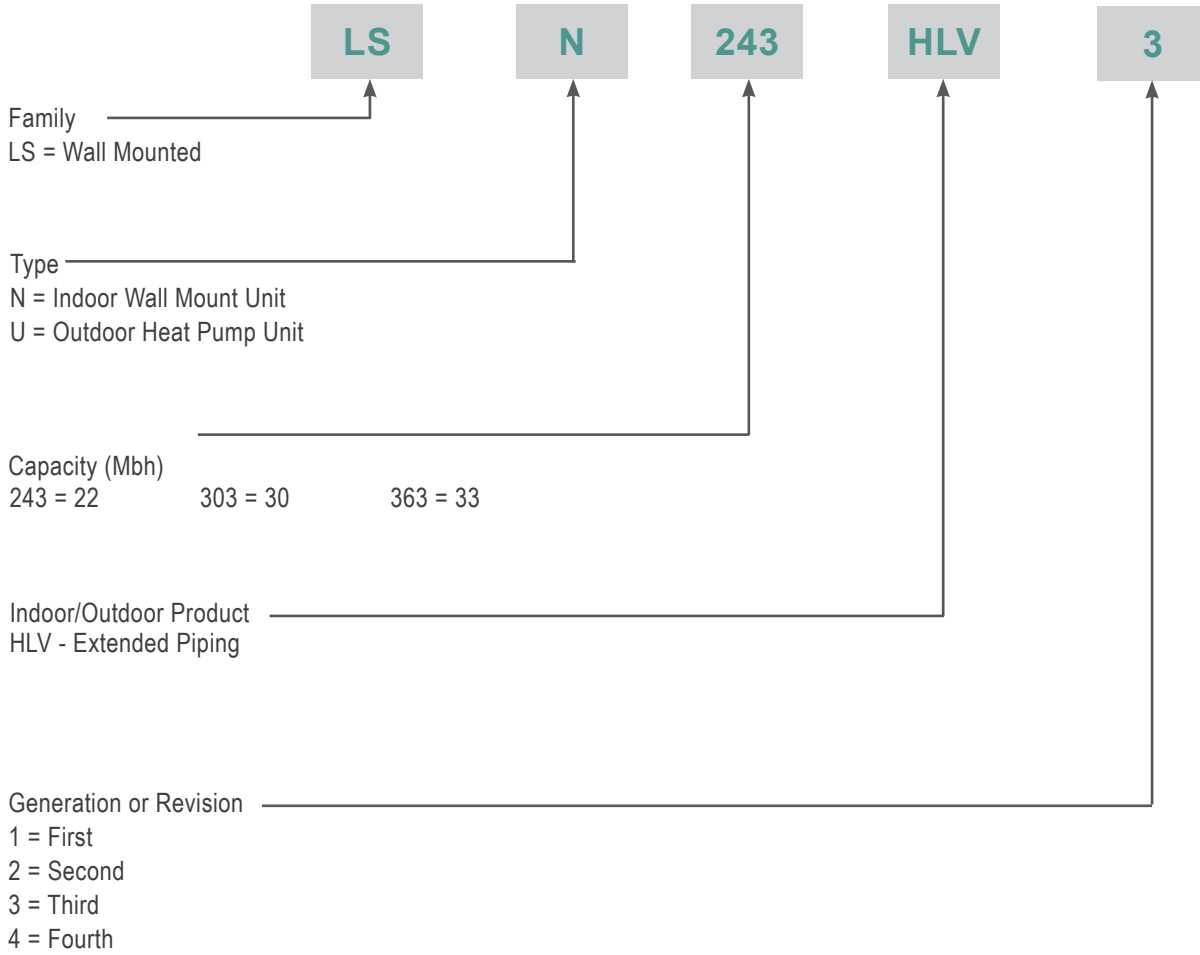

LG AIR CONDITIONER TECHNICAL SOLUTION (LATS)

LG Air Conditioner Technical Solution (LATS) Software

A properly designed and installed refrigerant piping system is critical to the optimal performance of LG air-conditioning systems. To assist engineers, LG offers, free of charge, LG Air Conditioner Technical Solution (LATS) software—a total design solution for LG air conditioning systems. Contact your LG Rep for the best software program for your application.

Note:

To reduce the risk of designing an improper applied system or one that will not operate correctly, LG requires that LATS software be used on all projects.

Formats

LATS is available to LG customers in three user interfaces: LATS HVAC, LATS CAD2, and LATS Revit. All three LATS formats are available through www.myLGHVAC.com, or contact an LG Sales Representative.

LATS HVAC is a Windows®-based application that aids engineers in designing LG Variable Refrigerant Flow (VRF), Multi F / Multi F MAX, Single-Zone, and Energy Recovery Ventilator (ERV) systems.

*Windows® is a registered mark of Microsoft® Corporation.

LATS CAD2 combines the LG LATS program with AutoCAD® software**. It permits engineers to layout and validate LG Multi V Variable Refrigerant Flow (VRF), Multi F / Multi F MAX, Single-Zone, and Energy Recovery Ventilator (ERV) systems directly into CAD drawings.

LATS Revit integrates the LG LATS program with Revit® software**. It permits engineers to layout and validate Multi V VRF systems directly into Revit drawings.

**AutoCAD® and Revit® are both registered marks of Autodesk, Inc.

Features

All LG product design criteria have been loaded into the program, making LATS simple to use: double click or drag and drop the component choices. Build systems in Tree Mode where the refrigerant system can be viewed. Switch to a Schematic diagram to see the electrical and communications wiring.

LATS software permits the user to input region data, indoor and outdoor design temperatures, modify humidity default values, zoning, specify type and size of outdoor units and indoor units, and input air flow and external static pressure (ESP) for ducted indoor units.

The program can also:

- Import building loads from a separate Excel file.
- Present options for outdoor unit auto selection.
- Automatically calculate component capacity based on design conditions for the chosen region.
- Verify if the height differences between the various system components are within system limits.
- Provide the correct size of each refrigerant piping segment and LG Y-Branches and Headers.
- Adjust overall piping system length when elbows are added.
- Check for component piping limitations and flag if any parameters are broken.
- Factor operation and capacity for defrost operation.
- Calculate refrigerant charge, noting any additional trim charge.
- Suggest accessories for indoor units and outdoor units.
- Run system simulation.

Note:

Features depend on which LATS program is being used, and the type of system being designed.

Figure 1: Example of LATS CAD2.



LG AIR CONDITIONER TECHNICAL SOLUTION (LATS)

LATS Generates a Complete Project Report

LATS software also generates a report containing project design parameters, cooling and heating design data, system component performance, and capacity data. The report includes system combination ratio and refrigerant charge calculations; and provides detailed bill of material, including outdoor units, indoor units, control devices, accessories, refrigerant pipe sizes segregated by building, by system, by pipe size, and by pipe segments. LATS can generate an Excel GERP report that can imported into the LG SOPS pricing and ordering system.

Proper Design to Install Procedure

LG encourages a two report design-to-install-procedure. After the design engineer determines building / zone loads and other details, the engineer opens the LATS program and inputs the project's information. When the design is complete, the "Auto Piping" and "System Check" functions must be used to verify piping sizes, limitations, and if any design errors are present. If errors are found, engineers must adjust the design, and run Auto Piping and System Check again. When the design passes the checks, then the engineer prints out a project "Shop Drawing" (LATS Tree Diagram) and provides it to the installing contractor. The contractor must follow the LATS Tree Diagram when building the piping system, but oftentimes the design changes on the building site:

- Architect has changed location and/or purpose of room(s).
- Outdoor unit cannot be placed where originally intended.
- Structural elements prevent routing the piping as planned.
- Air conditioning system conflicts with other building systems (plumbing, gas lines, etc.).

The contractor must mark any deviation from the design on the Shop Drawing, including as-built straight lines and elbows. This "Mark Up" drawing must be returned to the design engineer or Rep, who must input contractor changes into the LATS file. (Copy the original LATS software file, save and rename as a separate file, and modify all piping lengths by double-clicking on each length and editing information.) Like the shop drawing, the Auto Piping and System Check must also be run on this new "As Built" drawing. The design engineer or Rep must then provide the final As Built file to the contractor. The Mark Up version must be compared to the As Built version for:

- Differences in pipe diameter(s). If incorrect diameters have been installed, the piping must be changed out. If pipe diameters have changed, check to see if Y-Branches will also need to be changed.
- Changes to outdoor unit and indoor unit capacities. Capacities changes will impact line length changes.
- Additional refrigerant charge quantity ("Trim Charge"). Trim charge will change if piping lengths and diameters change. The As Built version must reflect installed piping lengths to ensure correct trim charge.

All documents submitted by the contractor, as well as the Shop Drawing and the As Built Drawing files must be provided for commissioning purposes. Model and serial numbers for all system components must also be submitted. If the steps previously detailed are not followed, and all documents are not provided to the commissioning agent, the project runs the risk of not being commissioned and voiding any limited warranty LG offers on the equipment.

Note:

Contact your LG representative for the best software program for your application.

Figure 2: Example of a LATS Tree Diagram.

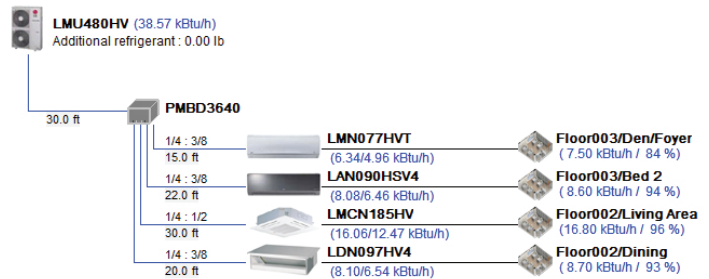

PRODUCT DATA

Mechanical Specifications on page 8

General Data on page 9

Electrical Data on page 11

Functions, Controls, Options on page 12

Outdoor Unit Dimensions on page 13

Outdoor Unit Center of Gravity / Corner Weight on page 14

Indoor Unit Dimensions on page 15

Acoustic Data on page 17

Refrigerant Flow Diagram on page 21

Indoor Unit Wiring Diagram on page 22

Outdoor Unit Wiring Diagram on page 23

Electrical Connections on page 24

Air Flow, Static Pressure, and Temperature Distribution on page 28

MECHANICAL SPECIFICATIONS

Extended Piping Wall Mounted System

General

LG Single Zone Wall Mounted Extended Piping systems are comprised of a single outdoor unit connected to a single indoor unit with a single refrigerant circuit.

These single zone systems can operate in either cooling or heating mode. These systems are capable of changing mode within a maximum time of three (3) minutes to ensure temperature can be properly maintained.

LG components are manufactured in a facility registered to ISO 9001 and ISO 14001, which is a set of standards applying to environmental protection set by the International Organization for Standardization (ISO). Wiring in these units are in accordance with the National Electrical Code (NEC).

Temperature Ranges

Outdoor Unit

Operating ranges for outdoor units of 14°F to 118°F DB for cooling and -4°F to 65°F WB for heating.

Indoor Unit

Operating ranges for indoor units of 53°F to 75°F WB for cooling and 60°F to 86°F DB for heating.

Installing an optional Low Ambient Wind Baffle Kit will allow operation down to 0°F in cooling mode for all single zone systems.

Casing / Frame

Outdoor unit is constructed with pre-coated metal (PCM).

Indoor unit is constructed of heavy duty Acrylonitrile Butadiene Styrene (ABS) and High Impact Polystyrene (HIPS) plastic.

Refrigerant System

The refrigeration system consists of a single refrigeration circuit and uses R410A refrigerant. The outdoor unit is provided with factory installed components, including a refrigerant strainer, four-way reversing valve, electronic controlled expansion valve (EEV), high and low side charging ports, service valves, and interconnecting piping.

Refrigeration Oil Control

Heat pump outdoor units have a centrifugal oil separator and controls to ensure sufficient oil supply is maintained, and that oil does not travel with the refrigerant.

Compressors

The outdoor unit is equipped with one hermetic digitally controlled inverter driven twin rotary compressor to modulate capacity (modulation in 1 Hz increments).

Frequency ranges for the outdoor units are as follows:

LSU243HLV3: 10 Hz ~ 70 Hz for Cooling;
10 Hz ~ 100 Hz for Heating.

LSU303HLV3: 10 Hz ~ 60 Hz for Cooling;
10 Hz ~ 90 Hz for Heating.

LSU363HLV3: 10 Hz ~ 64 Hz for Cooling;
10 Hz ~ 90 Hz for Heating.

Overcurrent protection and vibration isolation are integrated with the compressor.

Outdoor Unit Coil

Heat pump outdoor unit coils are made of a nonferrous construction with louvered fins on copper tubing, and are protected with an integral coil guard. Coil fins have a factory applied corrosion resistant GoldFin™ material with hydrophilic coating. Outdoor units include factory-installed drain pan heaters.

Fans and Motors

The outdoor unit includes one direct fan drive, variable speed variable speed propeller type fan.

The Brushless Digitally Controlled (BLDC) fan motor included inherent protection, permanently lubricated bearings, and variable speed with a maximum speed up to 950 rpm. Raised guards are provided to limit contact with moving parts.

The outdoor unit has horizontal discharge airflow.

Figure 3: LS303HLV3 and LS363HLV3 Extended Piping Wall Mounted System.



Electrical

These units are available in 208-230V, 60 Hz, 1-phase power supply. These units are capable of operating within voltage limits of $\pm 10\%$ rated voltage, and include overcurrent protection.

Controls

The indoor unit casing has a factory-standard, integral, infrared sensor designed to communicate with the supplied LG wireless handheld remote controller. An optional LG supplied wired controller is available as an additional accessory. Communication between the indoor unit and the outdoor unit is accomplished through 14 AWG four-core, stranded, shielded power / communication cable.





HLV3 indoor units have built-in Wi-Fi and can be controlled by LG's Smart ThinQ™ app on a smartphone. A field-supplied Wi-Fi network and smart device are required. The Smart ThinQ app is free, and is available for Android™ and iOS. (Android is a trademark of Google LLC.)

GENERAL DATA

Extended Piping Wall Mounted System Pairing Table

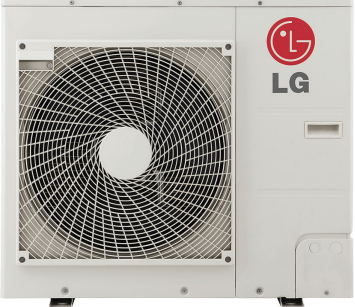
The following tables show the available outdoor and indoor units, along with the factory provided controllers.

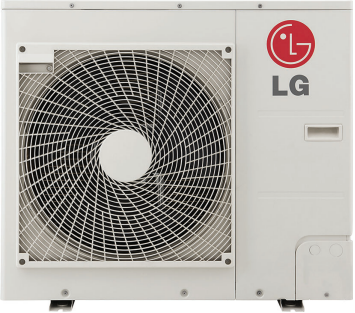
Table 1: Single Zone Wall Mounted Extended Piping System Pairing Table

Outdoor Unit Model	Indoor Unit Model	Controller
<p data-bbox="297 468 431 491">LSU243HLV3</p> 	<p data-bbox="816 468 951 491">LSN243HLV3</p> 	<p data-bbox="1263 468 1398 491">AKB74955602</p> 
<p data-bbox="297 873 431 926">LSU303HLV3 LSU363HLV3</p> 	<p data-bbox="816 873 951 926">LSN303HLV3 LSN363HLV3</p> 	<p data-bbox="1263 873 1398 896">AKB74955602</p> 

Product Data

GENERAL DATA

Extended Piping Wall Mounted System Specifications

Table 2: Single Zone Extended Piping Wall Mounted Specifications.

System (Model) (Indoor Unit / Outdoor Unit)	LS243HLV3 (LSN243HLV3/LSU243HLV3)	LS303HLV3 (LSN303HLV3/LSU303HLV3)	LS363HLV3 (LSN363HLV3/LSU363HLV3)
Cooling Capacity ¹ (Min/Rated/Max) (Btu/h)	3,070 ~ 22,000 ~ 30,000	3,070 ~ 30,000 ~ 34,000	3,070 ~ 33,000 ~ 34,000
Cooling Power Input ¹ (Rated) (kW)	1.69	2.66	3.30
Heating Capacity (Min/Rated/Max) (Btu/h)	3,070 ~ 26,000 ~ 36,200	3,070 ~ 32,400 ~ 38,900	3,070 ~ 35,200 ~ 38,900
Heating Power Input ¹ (Rated) (kW)	2.08	2.75	3.12
COP	12.50	11.80	11.30
Maximum Heating Capacity (Btu/h)			
Outdoor 17°F (WB)/Indoor 70°F (DB)	27,360 (105%)	32,500 (100%)	35,740 (102%)
Outdoor 5°F (WB)/Indoor 70°F (DB)	23,700 (91%)	28,080 (88%)	30,890 (88%)
Outdoor 0°F (WB)/Indoor 70°F (DB)	22,710 (87%)	26,180 (81%)	28,800 (82%)
Outdoor -4°F (WB)/Indoor 70°F (DB)	21,170 (81%)	24,390 (75%)	26,820 (76%)
EER	13.00	11.30	10.00
SEER	21.50	20.00	18.50
HSPF	12.00	11.50	11.00
Power Supply V, Ø, Hz ²	208-230/60/1		
Outdoor Unit Operating Range³			
Cooling (°F DB)	14 to 118		
Heating (°F WB)	-4 to +65		
Indoor Unit Operating Range			
Cooling (°F WB)	53 to 75		
Heating (°F DB)	60 to 86		
Unit Data			
Refrigerant Type ⁴	R410A		
Refrigerant Control	EEV		
IDU Sound Pressure Level dB(A) (Cooling) (H/M/L/SL) ⁵	49 / 44 / 40 / 30	51 / 47 / 43 / 33	51 / 47 / 43 / 33
ODU Sound Pressure Level dB(Cooling/Heating) (A) ⁵	55 / 56	55 / 58	55 / 58
Unit Weight (lbs.)			
IDU (Net/Shipping)	36.6 / 44.5	40.8 / 48.9	40.8 / 48.9
ODU (Net/Shipping)	135.4 / 147.7	147.9 / 160.3	147.9 / 160.3
Power Wiring / Communications Cable (No. x AWG) ⁶	4 x 14	4 x 14	4 x 14
Compressor			
Compressor (Qty.)	Twin Rotary (1)	Twin Rotary (1)	Twin Rotary (1)
Fan			
IDU Type x Qty.	Cross Flow Fan (1)		
ODU Type x Qty.	Propeller (1)		
Motor / Drive	Brushless Digitally Controlled / Direct		
Airflow Rate			
IDU (Cooling) (Max. / H / M / L [CFM])	813 / 601 / 495 / 389	1,095 / 883 / 742 / 601	1,095 / 883 / 742 / 601
ODU (Max. [CFM])	2,119	2,295	2,295
Piping			
Liquid (in.)	3/8 Flare	3/8 Flare	3/8 Flare
Vapor (in.)	5/8 Flare	5/8 Flare	5/8 Flare
Condensate Drain O.D. / I.D. (in.)	25/32, 19/32	25/32, 19/32	25/32, 19/32
Additional Refrigerant Charge (oz./ft.)	0.38	0.38	0.38
Pipe Length ⁷ (Minimum / Maximum) (ft.)	9.8 / 164.0	9.8 / 164.0	9.8 / 164.0
Piping Length ⁷ (no add'l refrigerant, ft.)	24.6	24.6	24.6
Max. Elevation Difference (ft.)	98.4	98.4	98.4

EEV: Electronic Expansion Valve IDU: Indoor Unit ODU: Outdoor Unit

This unit comes with a dry helium charge.

This data is rated 0 ft above sea level with 24.6 of refrigerant line per indoor unit and a 0 ft level difference outdoor and indoor units.

Cooling capacity rating obtained with air entering the indoor unit at 80°F dry bulb (DB) and 67°F wet bulb (WB) and outdoor ambient conditions of 95°F dry bulb (DB) and 75°F wet bulb (WB). Heating capacity rating obtained with air entering the indoor unit at 70°F dry bulb (DB) and 59°F wet bulb (WB) and outdoor ambient conditions of 47°F dry bulb (DB) and 43°F wet bulb (WB).

¹Power Input is rated at high speed.

²Power wiring to the ODU is field supplied, solid or stranded, and must comply with the applicable local and national codes.

³Low Ambient Wind Baffle Kit (sold separately) allows operation down to 0°F in cooling mode.

⁴Take appropriate actions at the end of HVAC equipment life to recover, recycle, reclaim or destroy R410A refrigerant according to applicable regulations (40 CFR Part 82, Subpart F) under section 608 of CAA.

⁵Sound pressure levels are tested in an anechoic chamber under ISO Standard 3745.

⁶All communication / connection (power) cable from the outdoor unit to the indoor unit is field supplied and must be a minimum of four-conductor, 14 AWG, stranded, shielded or unshielded (if shielded, it must be grounded to the chassis of the outdoor unit only), and must comply with applicable local and national codes. For detailed electrical information, please refer to electric characteristics on page 11.

⁷Piping lengths are equivalent.

ELECTRICAL DATA

Extended Piping Wall Mounted Systems

Table 3: 208-230V, 60Hz, 1-Phase Single-Zone Extended Piping Wall-Mounted Electrical Data.

Nominal Tons	Unit Model Number	Hertz	Voltage	Voltage Range (Min. to Max.)	MCA	MOP	Compressor Qty.	Compressor Motor RLA		Outdoor Fan Motor		Indoor Fan Motor	
								Cooling	Heating	W	FLA	W	FLA
2	LS243HLV3	60	208 - 230	187 - 253	19.0	30	1	14.41	14.41	124	0.4	58	0.5
2-1/2	LS303HLV3				23.0	30	1	15.1	15.1	124	0.25	110	0.5
2-3/4	LS363HLV3				23.0	30	1	15.1	15.1	124	0.25	110	0.5

Voltage tolerance is ±10%.

Maximum allowable voltage unbalance is 2%.

MCA = Minimum Circuit Ampacity.

Maximum Overcurrent Protection (MOP) is calculated as follows: (Largest motor FLA x 2.25) + (Sum of other motor FLA) rounded down to the nearest standard fuse size.

RLA = Rated Load Amps.

FLA = Full Load Amps.

FUNCTIONS, CONTROLS, OPTIONS

Table 4: Indoor Units—Functions, Controls and Options.

Indoor Unit Type		LS243HLV3	LS303HLV3	LS363HLV3
Airflow	Air Supply Outlet	1	1	1
	Airflow Direction Control (Left / Right)	5 Steps	5 Steps	5 Steps
	Airflow Direction Control (Up / Down)	6 Steps	6 Steps	6 Steps
	Auto Swing (Left / Right)	√	√	√
	Auto Swing (Up / Down)	√	√	√
	Fan Speed Airflow Steps (Fan / Cool / Heat)	6 / 6 / 6	6 / 6 / 6	6 / 6 / 6
	Natural Wind (Auto Wind)	√	√	√
	Jet Cool / Jet Heat (Power Wind)	√ / √	√ / √	√ / √
	Comfort Air	√	√	√
Air Purifying	Washable Anti-Bacteria Prefilter ¹	√	√	√
	Deodorizing Filter	X	X	X
	Plasma	X	X	X
	Micro Dust Filter	X	X	X
	Allergy Filter	X	X	X
Functions	Hot Start	√	√	√
	Self Diagnostics	√	√	√
	Defrost	√	√	√
	Dry (Dehumidification Operation)	√	√	√
	Auto Changeover	√	√	√
	Auto Cleaning (Coil Dry)	√	√	√
	Auto Restart	√	√	√
	Child Lock (Applicable with Wired Controller)	o	o	o
	Forced Operation	√	√	√
	Sleep Mode	√ / 7 Hour	√ / 7 Hour	√ / 7 Hour
	Timer 24 hour (On / Off)	√	√	√
	Weekly Timer (Applicable with Wired Controller)	o	o	o
	Two Thermistor Control	o	o	o
	Low Ambient	√	√	√
	Overheating Protection	√	√	√
	Low Heating	√	√	√
	Smart Diagnosis	√	√	√
	Indoor Display Type	Number Display	Number Display	Number Display
	Indoor Unit Display Light	On / Off	On / Off	On / Off
	Energy Saving	√	√	√
Drain Pan Heater	√	√	√	
Controllers	Wireless Handheld Remote Controller	√ (AKB74955602)		
	Programmable Controllers (MultiSITE CRC1 / CRC1+)	o (PREMTBVC0 / PREMTBVC1)		
	Simple Remote Controller	o (PREMTC00U)		
	Premium Remote Controller	o (PREMTA000)		
	Dry Contact	o (PDRYCB100 / 300 / 400)		
	Network Solution (LGAP)	o	o	o
Central Controllers / Integration Solutions	AC Smart 5	o (PACS5A000)		
	ACP 5	o (PACP5A000)		
	PI-485	o (PMNFP14A1)		
	MultiSITE Communications Manager	o (PBACNBTR0A)		
	MultiSITE VM3	o (PBACNBTR1B)		
Special Functions	Wi-Fi Module (Built In)	√	√	√
	Water Level Sensor Connection (for Optional AG-9300-LG)	o	o	o
	Wind Baffle Kit	o (ZLABGP04A)		
Other	Mode Lock	Cooling Only or Heating Only		
	Temperature Control	Thermistor		
	Smart Inverter Monitoring System (SIMS)	o (PSWMOZ3)		

¹Primary washable filters.

- √ = Standard feature
- o = Optional accessory (must be purchased separately)
- X = Not available

- When Dry Contact Mode active, Wi-Fi Function can not be used.
- When changing from Wi-Fi mode to dry contact mode, normal operation resumes in approximately 3 minutes.

OUTDOOR UNIT DIMENSIONS

LSU243HLV3, LSU303HLV3, LSU363HLV3

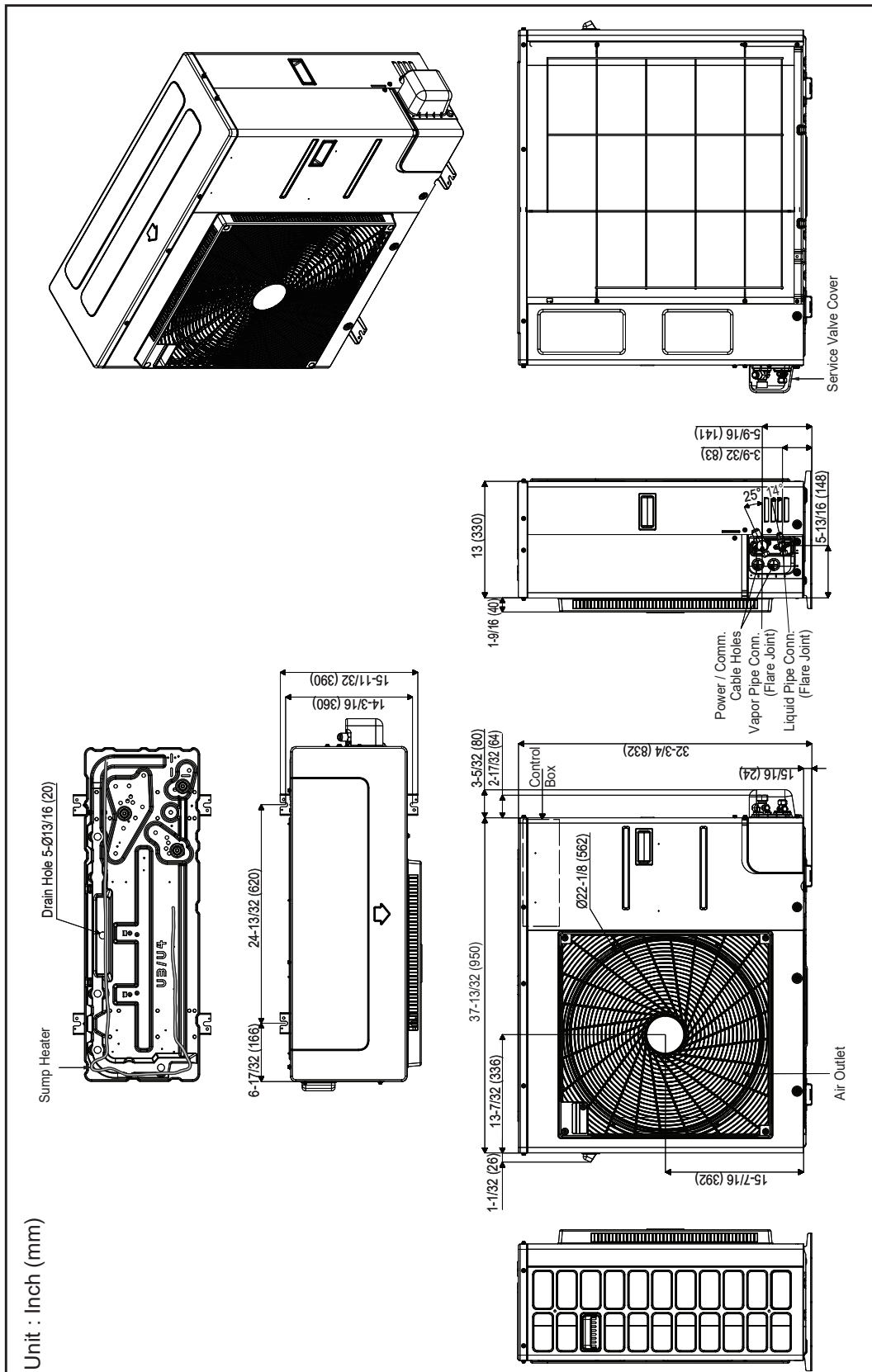

OUTDOOR UNIT CENTER OF GRAVITY / CORNER WEIGHT

Figure 4: Center of Gravity and Corner Weight Dimensions Diagram.

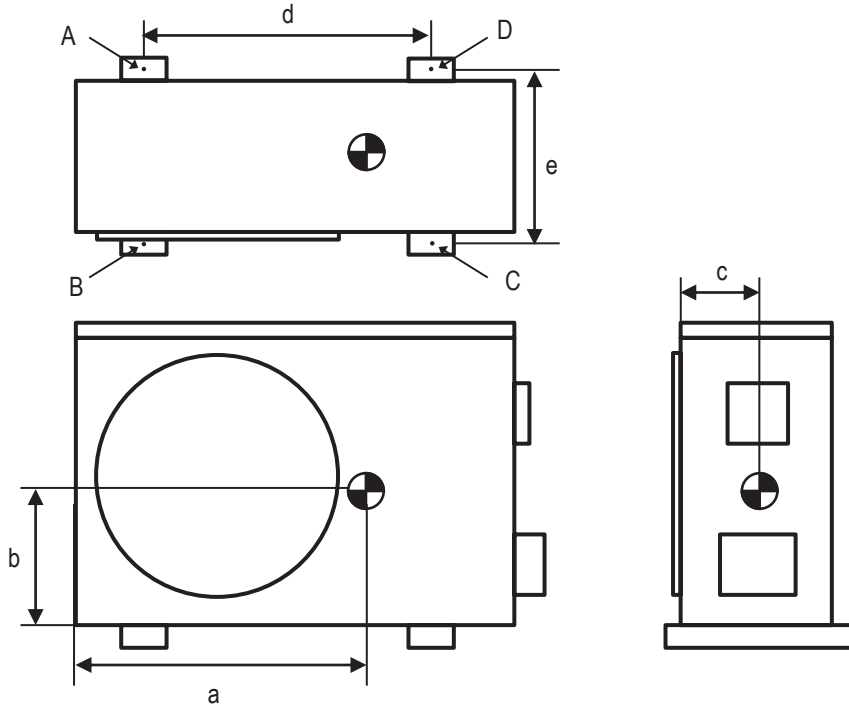

Table 5: Center of Gravity and Corner Weight Dimensions.

Model	Weight (lb.)		Center of Gravity (inch)			Leg (inch)		Corner Weight (lb.)			
	Shipping	Net	a	b	c	d	e	A	B	C	D
LSU243HLV3	147.7	135.4	23-7/32	12-19/32	5-29/32	24-13/32	14-3/16	18.6	24.2	49.1	43.5
LSU303HLV3, LSU363HLV3	160.3	147.9	23-7/32	12-19/32	5-29/32	24-13/32	14-3/16	20.3	26.5	53.7	47.4

INDOOR UNIT ACOUSTIC DATA

Extended Piping Wall Mounted Systems

Indoor Unit Sound Pressure Measurement / Sound Pressure Levels

Figure 5: Extended Piping Wall Mounted Indoor Unit Sound Level Measurement Location.

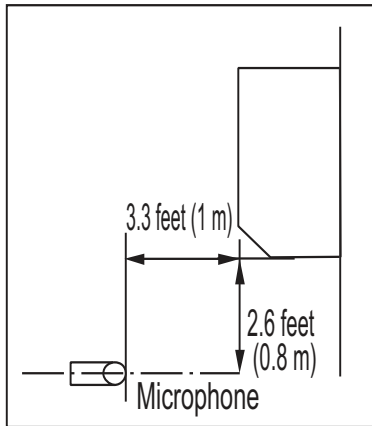

- Measurements are taken 3.3 feet (1 m) away from the front of the unit.
- Sound pressure levels are measured in dB(A) with a tolerance of ± 1 .
- Reference acoustic pressure $0\text{dB}=20\mu\text{Pa}$.
- Data is valid at nominal operation conditions. Operating conditions are assumed to be standard.
- Sound pressure levels are tested in an anechoic chamber under ISO Standard 3745, and may be different according to the test condition or equipment.
- Sound level will vary depending on a range of factors including the construction (acoustic absorption coefficient) of a particular room in which the unit was installed.

Table 6: Extended Piping Wall Mounted Indoor Unit Sound Pressure Data.

Model	Cooling			Heating		
	H	M	L	H	M	L
LSN243HLV3	49	44	40	49	44	40
LSN303HLV3	51	47	43	51	47	43
LSN363HLV3	51	47	43	51	47	43

LSN243HLV3 Sound Pressure Levels

Figure 6: Sound Pressure Levels for LSN243HLV3 Indoor Units.

LSN243HLV3

Cooling

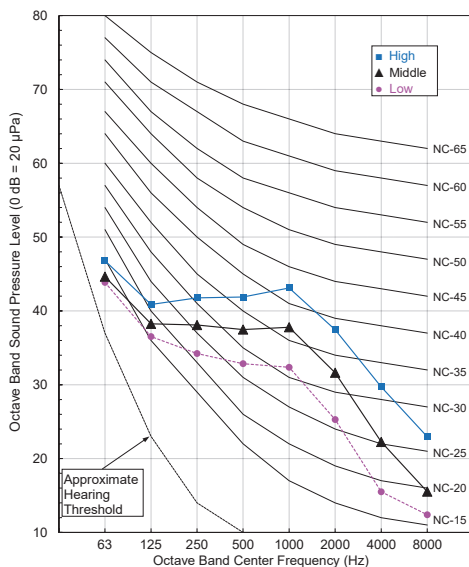

Heating

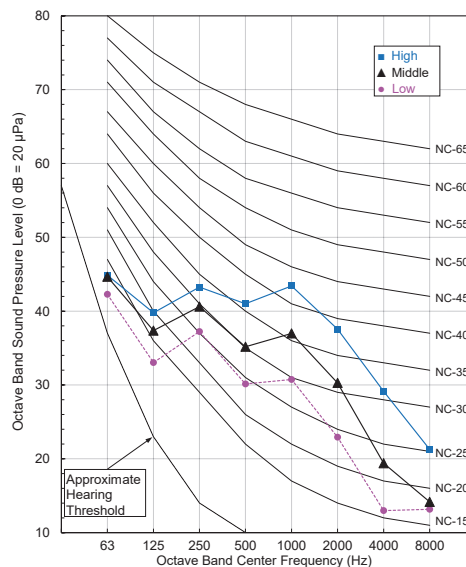

INDOOR UNIT ACOUSTIC DATA

Extended Piping Wall Mounted Systems

LSN303HLV3 and LSN363HLV3 Sound Pressure Levels

Figure 7: Sound Pressure Levels for LSN303HLV3 Indoor Units.

LSN303HLV3

Cooling

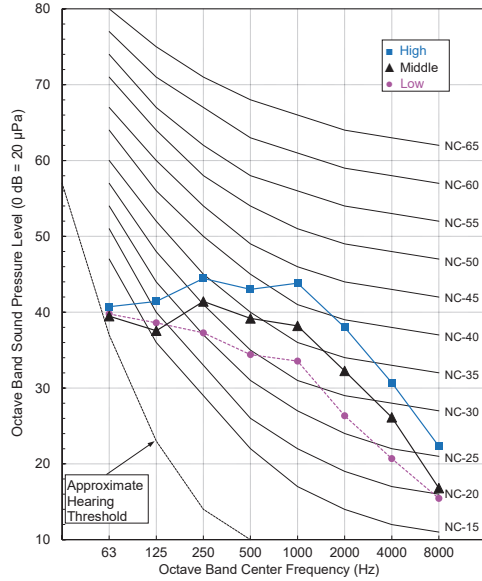

Heating

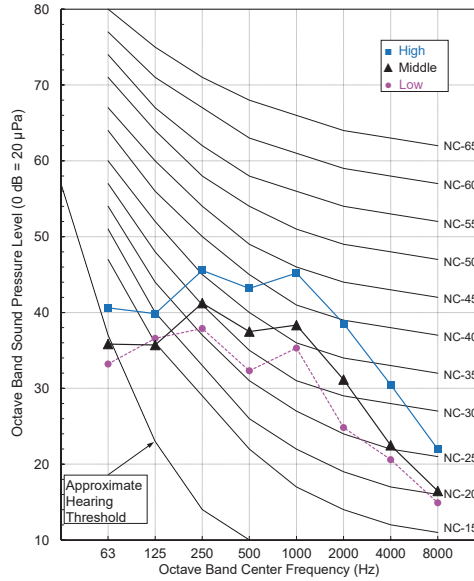
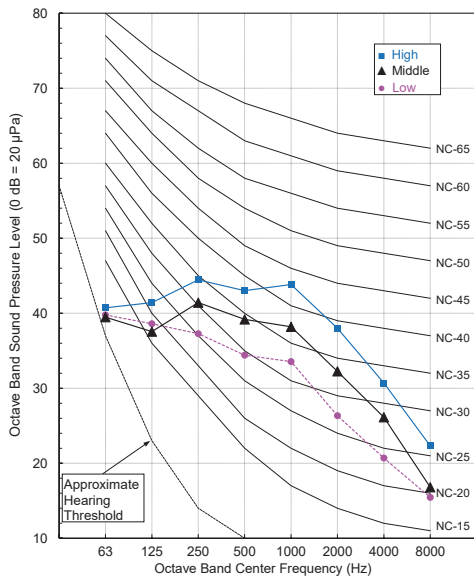

Figure 8: Sound Pressure Levels for LSN363HLV3 Indoor Units.

LSN363HLV3

Cooling



Heating

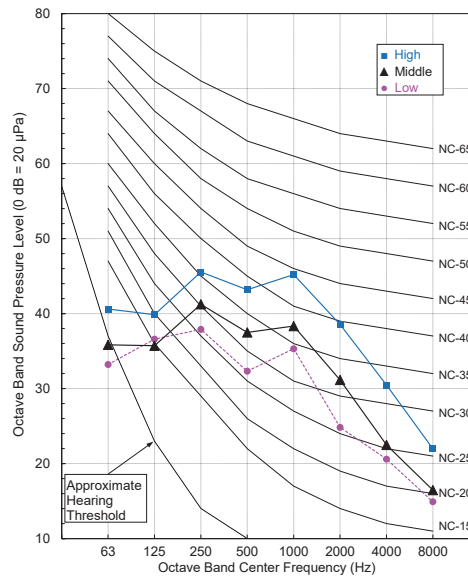

OUTDOOR UNIT ACOUSTIC DATA

Extended Piping Wall Mounted Systems

Outdoor Unit Sound Pressure Measurement / Sound Pressure Levels

Figure 9: Extended Piping Wall Mounted Outdoor Unit Sound Level Measurement Location.

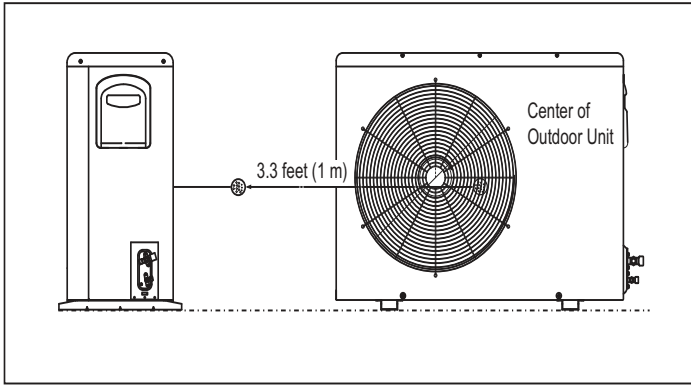

- Measurements are taken 3.3 feet (1 m) away from the front of the unit.
- Sound pressure levels are measured in dB(A) with a tolerance of ± 1 .
- Data is valid at nominal operation conditions. Operating conditions are assumed to be standard.
- Reference acoustic pressure $0\text{dB}=20\mu\text{Pa}$.
- Sound pressure levels are tested in an anechoic chamber under ISO Standard 3745, and may be different according to the test condition or equipment.
- Sound level will vary depending on a range of factors including the construction (acoustic absorption coefficient) of a particular room in which the unit was installed.

Table 7: Extended Piping Wall Mounted Outdoor Unit Sound Pressure Data.

Model	Cooling	Heating
	H	H
LSU243HLV3	55	56
LSU303HLV3	55	58
LSU363HLV3	55	58

LSU243HLV3 Sound Pressure Levels

Figure 10: Sound Pressure Levels for LSU243HLV3 Outdoor Units.

LSU243HLV3

Cooling

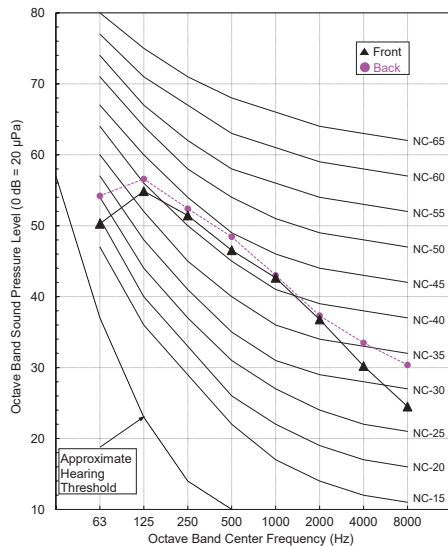

Heating

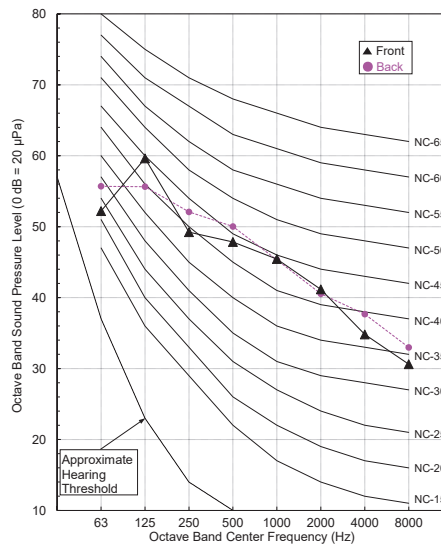

OUTDOOR UNIT ACOUSTIC DATA

Extended Piping Wall Mounted Systems

LSU303HLV3 and LSU363HLV3 Sound Pressure Levels

Figure 11: Sound Pressure Levels for LSU303HLV3 Outdoor Units.

LSU303HLV3

Cooling

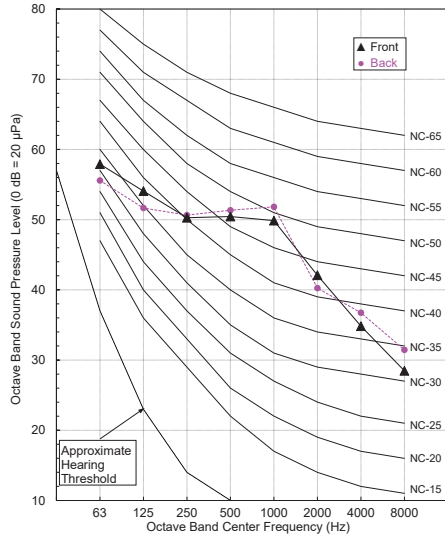

Heating

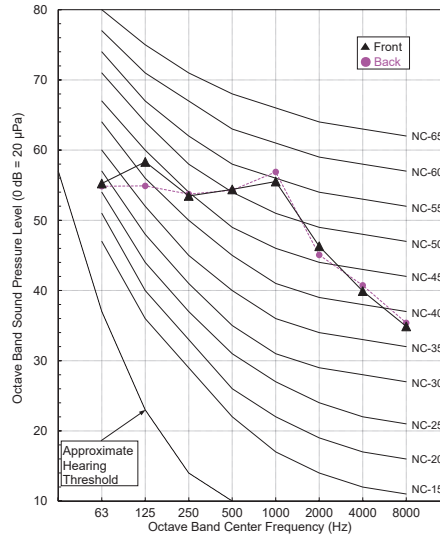
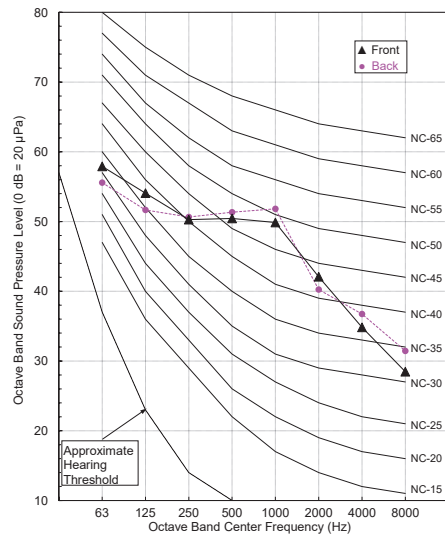

Figure 12: Sound Pressure Levels for LSU363HLV3 Outdoor Units.

LSU363HLV3

Cooling



Heating

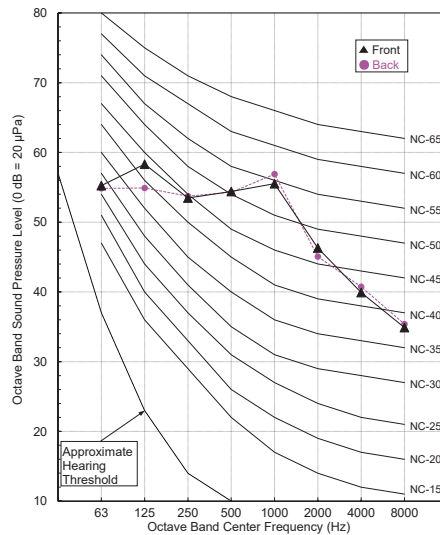

REFRIGERANT FLOW DIAGRAMS

LSU/LSN243HLV3, LSU/LSN303HLV3, LSU/LSN363HLV3

Refrigerant Flow Diagram for Extended Piping Wall Mounted Systems

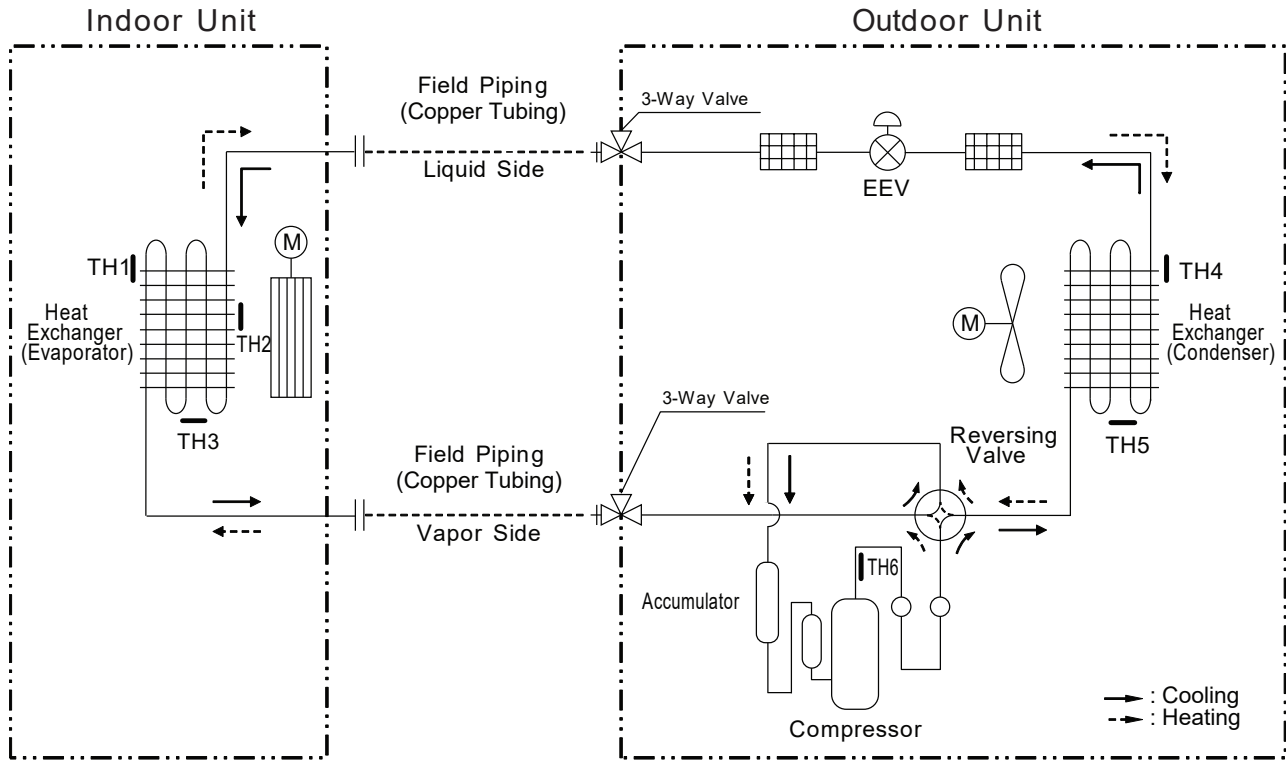

Table 8: LSN / LSU243-303-363HLV3 Thermistor Details.

Thermistor.	Description	PCB Connector
TH1	Indoor Air Temperature Thermistor	CN-TH1 (Indoor)
TH2	Evaporator Temperature Thermistor	CN-TH3 (Indoor)
TH3	Water Level Sensor (Optional)	CN-TH2 (Indoor)
TH4	Outdoor Air Temperature Thermistor	CN-TH1 (Outdoor)
TH5	Condenser Temperature Thermistor	
TH6	Discharge Pipe Temperature Thermistor	CH-TH2 (Outdoor)

Table 9: LSN / LSU243-303-363HLV3 Refrigerant Piping Sizes.

Model No.	Vapor (Inch [mm])	Liquid (Inch [mm])
LS243HLV3, LS303HLV3, LS363HLV3	Ø5/8 (Ø15.88)	Ø3/8 (Ø9.52)

Figure 13: LSN / LSU243-303-363HLV3 Refrigerant Piping Sizes.

Appendix	Heat Exchanger	Propeller Fan	Cross Flow Fan	Compressor	Accumulator	Reversing Valve (4 Way Valve)
	EEV (Electronic Expansion Valve)	Capillary Tube	2-Way Valve 3-Way Valve	Temperature Sensor	Pressure Sensor	Pressure Switch
	Check Valve	Flare Joint	Muffler	Strainer		

INDOOR UNIT WIRING DIAGRAM

LSN243HLV3, LSN303HLV3, LSN363HLV3

Wiring Diagram for Extended Piping Wall Mounted Indoor Units

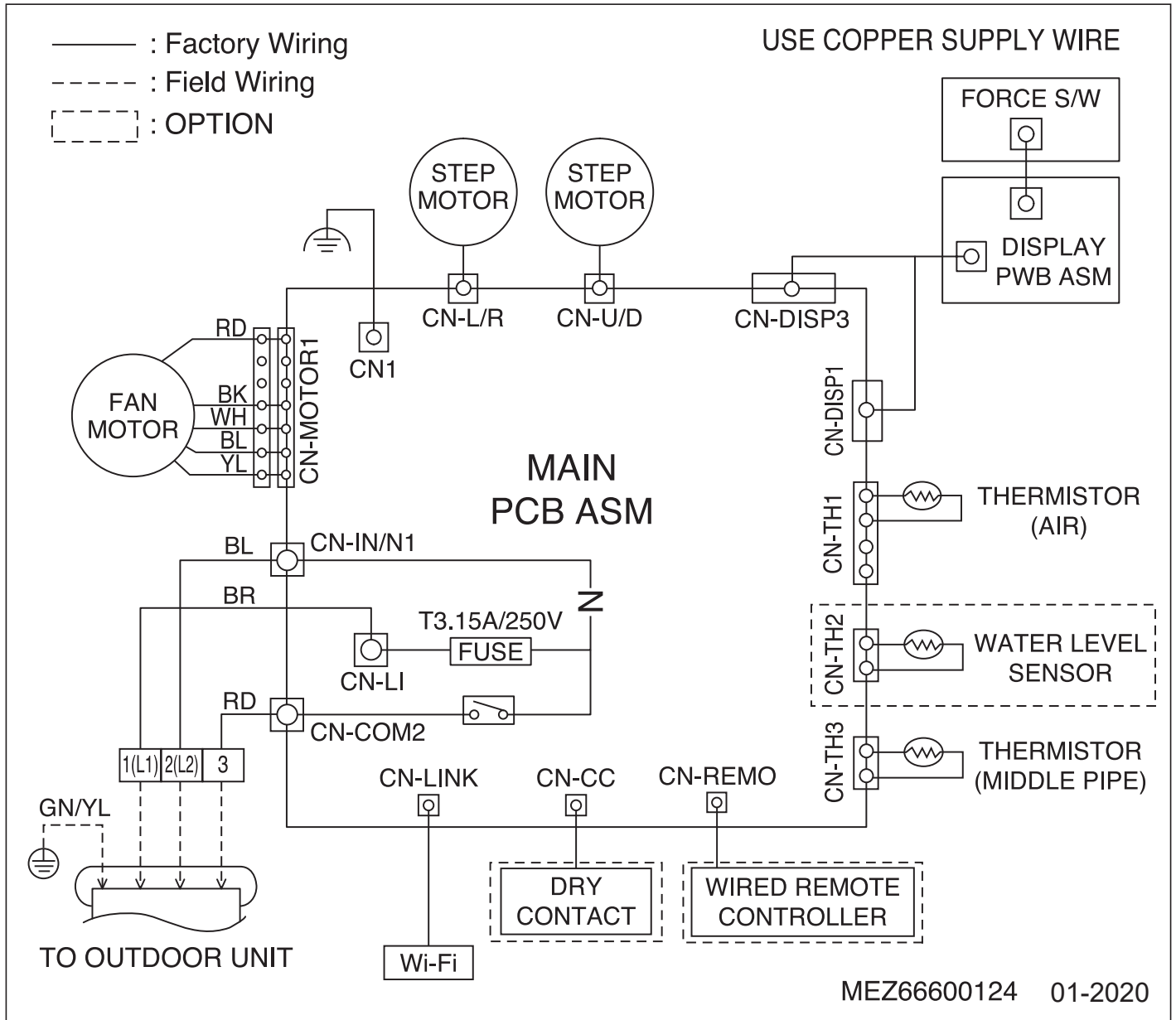

OUTDOOR UNIT WIRING DIAGRAM

LSU243HLV3, LSU303HLV3, LSU363HLV3

Wiring Diagram for Extended Piping Wall Mounted Outdoor Units

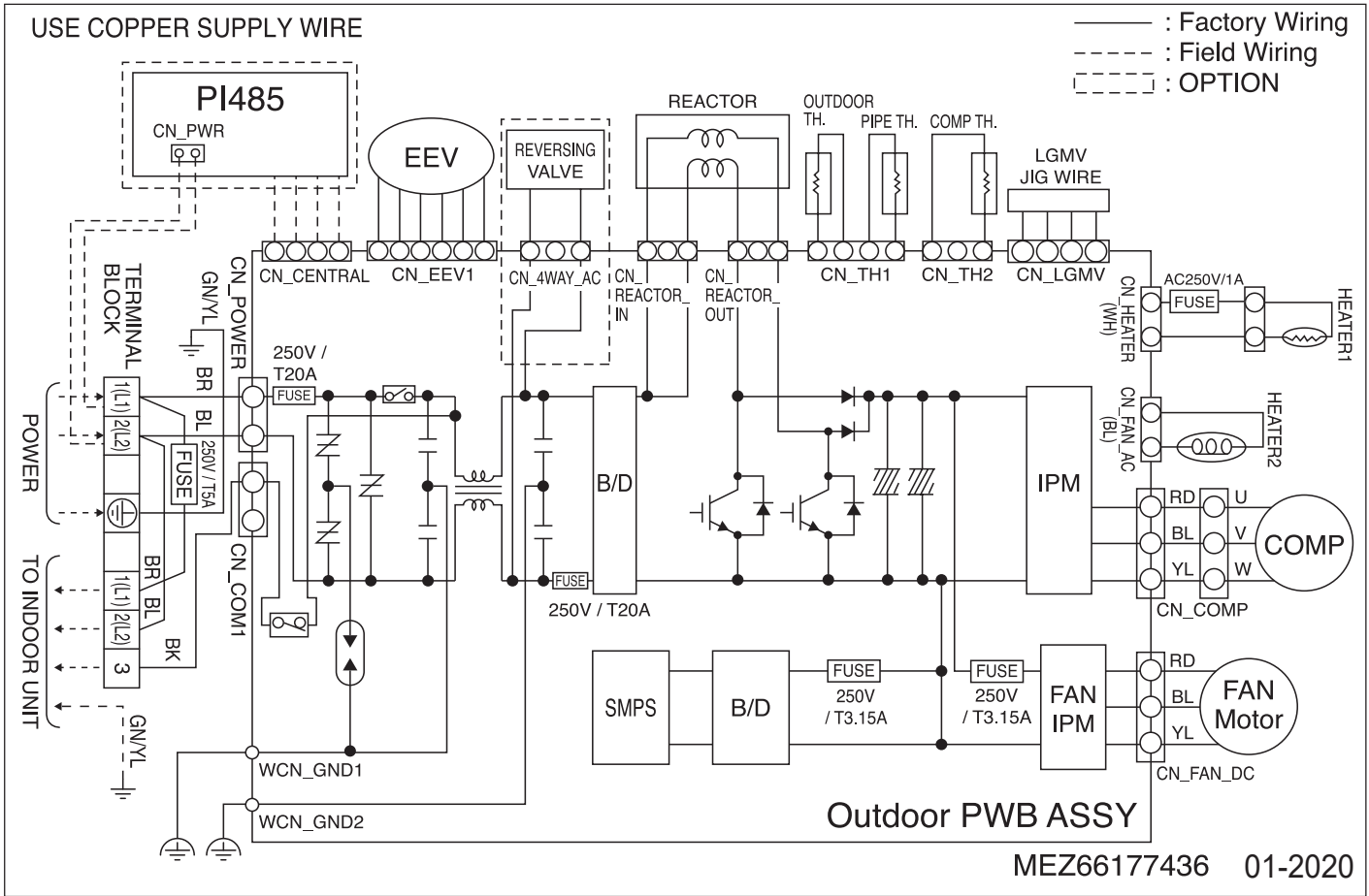

Product Data

ELECTRICAL CONNECTIONS

General Power Wiring / Communications Cable Guidelines

- Follow manufacturer's circuit diagrams displayed on the inside of the control box cover.
- Confirm power source specifications.
- Properly ground the outdoor unit and the indoor unit per National Electrical Code (NEC) and local codes.
- Connect the wiring firmly so that the wires cannot be easily pulled out.
- Confirm that the electrical capacity is sufficient.
- Power supply to the outdoor unit must be selected based on NEC and local codes. Maximum allowable voltage fluctuation $\pm 10\%$ or name-plate rated value.
- It is recommended that a circuit breaker is installed, especially if conditions could become wet or moist.
- Include a disconnect in the power wiring system. Add an air gap contact separation of at least 1/8 inch in each active (phase) conductor.
- Any openings where the field wiring enters the cabinet must be completely sealed.

Power Supply / Power Wiring

- LG Single Zone Extended Piping systems operate at 1 \emptyset , 208-230V, 60Hz.
- Power wiring / power wiring gauge to the outdoor unit(s) must be solid or stranded, and must comply with all National Electrical Code (NEC), UL, and local electrical codes.
- The indoor unit is powered by the outdoor unit. See the next page for communication / connection (power) cable specifications from the outdoor unit to the indoor unit.
- Ground wire must be longer than the common power / communication wires.
- Connect the wiring firmly so the wires cannot be easily pulled out.
- Always match color codes of each wire and follow wiring diagram.
-  Do not install power wiring to the outdoor unit and the communication / connection (power) cable to the indoor unit in the same conduit. Use separate conduits.

WARNING

- Terminal screws will become loose during transport. Properly tighten the terminal connections during installation or risk electric shock, physical injury, or death.
- Loose wiring will cause unit to malfunction, overheat, and catch fire, resulting in severe injury or death.

Note:

- Terminal screws will loosen during transport. Properly tighten the terminal connections during installation or risk equipment malfunction or property damage.
- Loose wiring will cause unit malfunction, the wires to burnout or the terminal to overheat and catch fire. There is a risk of equipment malfunction or property damage.

A voltage drop will cause the following problems:

- Magnetic switch vibration, fuse breaks, or disturbance to the normal function of an overload protection device.
- Compressor will not receive the proper starting current.

Figure 14: LS243HLV3 General Power / Communications System Schematic.

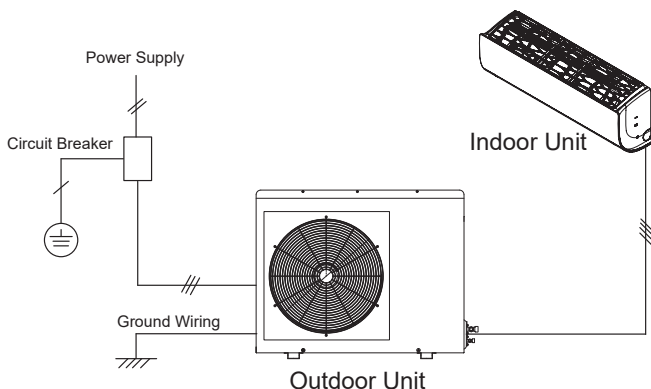
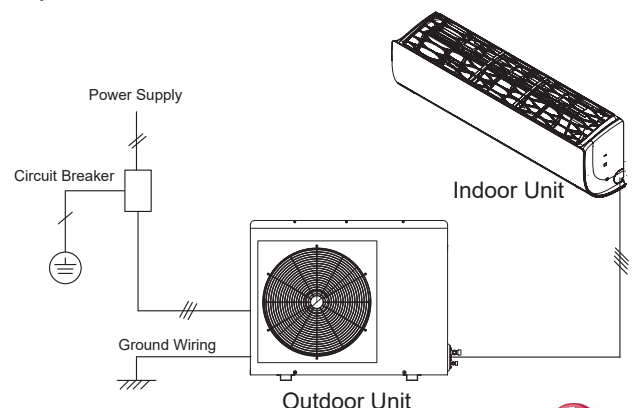

Figure 15: LS303HLV3 and LS363HLV3 General Power / Communications System Schematic.



Due to our policy of continuous product innovation, some specifications may change without notification.
© LG Electronics U.S.A., Inc., Englewood Cliffs, NJ. All rights reserved. "LG" is a registered trademark of LG Corp.

ELECTRICAL CONNECTIONS

Communication / Connection (Power) Cable Specifications from Outdoor Unit to Indoor Unit

- For communication / connection (power) wires between the Single Zone outdoor unit and the indoor unit for lengths up to 130 feet, use a minimum 14 gauge, four (4) conductor, stranded, shielded or unshielded wire. If shielded, the wire must be grounded to the chassis at the outdoor unit only.
- When the communication / connection (power) wires between the indoor unit and outdoor unit is GREATER THAN 130 feet, use:
 - A two (2) conductor wire for power.
 - A two (2) conductor wire for communication / ground.
 - Separate the power AT LEAST two (2) inches away from the communication / ground wire.
 - All wiring is still minimum 14 gauge, stranded, shielded, or unshielded as cited above.
- Insulation material as required by local code.
- Firmly attach the cable; provide slack but secure in a way to prevent external forces from being imparted on the terminal block.
- Wiring must be completed without splices.

⚠ WARNING

All power wiring and communication cable installation must be performed by trained service providers working in accordance with local, state, and National Electrical Code (NEC) / UL / ETL federal regulations related to electrical equipment and wiring, and following the manufacturer product diagrams, requirements, and instructions in this manual. Failure to do so will lead to electric shock which can cause physical injury or death.

Note:

- Always verify the communication cable is connected to a communications terminal on the Single Zone Extended Piping unit. ⚠ Never apply line voltage power to the communication cable connection. If contact is made, the PCBs will be damaged.
- The shield of the communications cable connecting the outdoor unit to the indoor unit must be grounded only to the outdoor unit frame.
- Tie the shield of each cable segment together using a wire nut at the indoor unit. Maintain polarity throughout the communication network.
- Position the incoming power to the outdoor unit away from the power / communications cables from the outdoor unit to the indoor unit.
- ⚠ Never use a common multiple-core communications cable.

Figure 18: Typical HLV3 Power / Communication System Diagram For Wiring Lengths Up to 130 Feet..

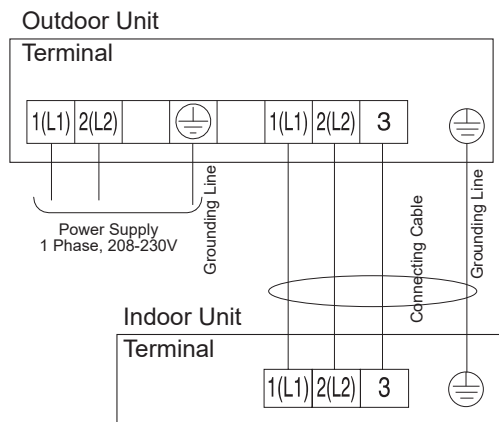
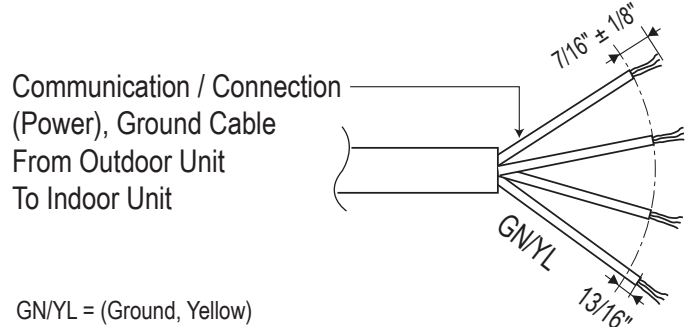
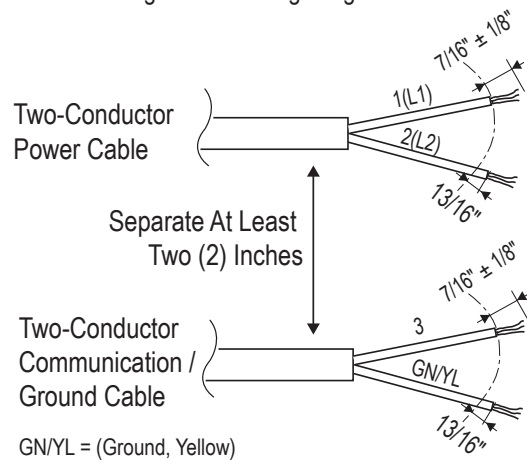

Figure 16: Typical Single Zone Outdoor Unit to Indoor Unit Wiring and Communications Cable Diagram For Wiring Lengths Up to 130 Feet.



GN/YL = (Ground, Yellow)

Figure 17: Single Zone Outdoor Unit to Indoor Unit Wiring and Communications Cable Diagram For Wiring Lengths GREATER THAN 130 Feet.



GN/YL = (Ground, Yellow)

Figure 19: HLV3 Power / Communication System Diagram For Wiring Lengths GREATER THAN 130 Feet.

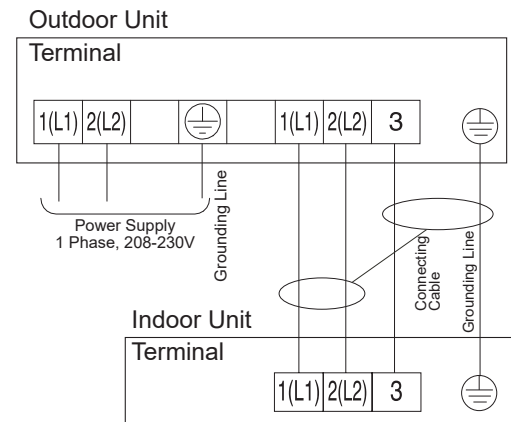

ELECTRICAL CONNECTIONS

Figure 23: Schematic of a Single Zone System When the Wiring is GREATER THAN 130 Feet.

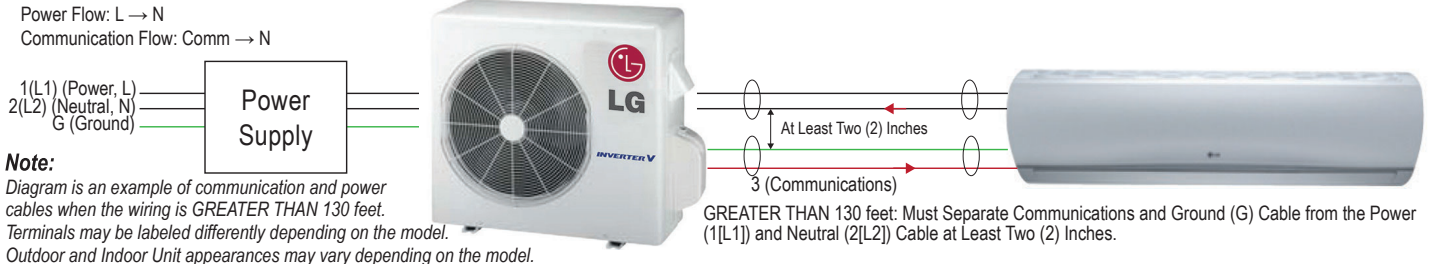

Note:
Diagram is an example of communication and power cables when the wiring is GREATER THAN 130 feet. Terminals may be labeled differently depending on the model. Outdoor and Indoor Unit appearances may vary depending on the model.

Note:

- Use a conduit for the communications cable / power wiring from the outdoor unit to the indoor unit.
- Make sure the communications cable / power wiring from the outdoor unit to the indoor unit, and the power wiring to the outdoor unit are separate, otherwise, the outdoor unit operation will be affected by electrical noise and will malfunction or fail.

Controller Options

Single Zone Extended Piping Wall Mounted systems include a wireless handheld remote controller (Part No. AKB74955602). Optional LG-supplied wired controllers are available. See “Functions, Controls, Options”, or contact an LG representative for more information.

Wireless Handheld Remote Controller features:

- Display Panel: Displays operation conditions.
- On / Off Button: Turns system operation on and off.
- Mode Button: Selects the operation mode: Cooling, Heating, Auto, Dry (Dehumidification), or Fan.
- Temp Up / Down Buttons: Adjusts the desired room temperature in the different modes.
- Fan Speed Button: Sets desired fan speed.
- Reset: Initializes the handheld remote control settings.

Wired Controller Connections

Optional controllers (see “Functions, Controls, Options”, or contact an LG representative for more information) can connect to the Extended Piping Wall Mounted indoor unit in one of two different ways:

1. LG Wired Remote Extension Cable with Molex plug (PZCWRC1; sold separately) that connects to the CN-REMO terminal on the indoor unit PCB.
2. Field-supplied controller cable that connects to the indoor unit terminal block (must be at least UL2547 or UL1007, and at least FT-6 rated if local electric and building codes require plenum cable usage). Communication cable from indoor unit to remote controller(s) is to be 22 AWG, 3-conductor, twisted, stranded, unshielded. Wiring must comply with all applicable local and national codes.

Figure 21: PZCWRC1 LG Wired Remote Extension Cable.

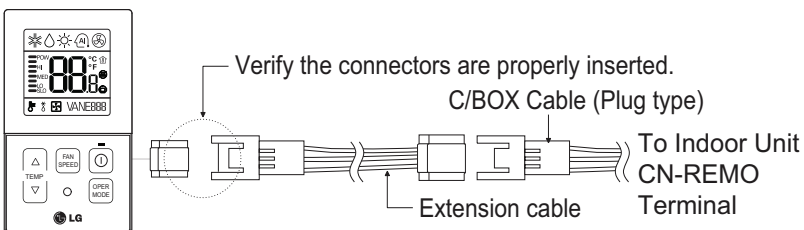
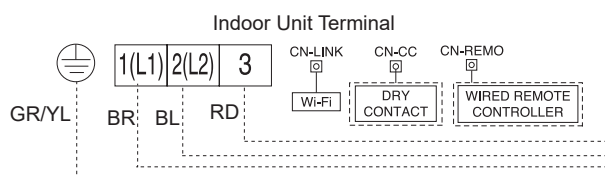

Figure 22: Wired Controller Connection (Example Only).



Note:

When using field-supplied controller cable, make sure to connect the yellow to yellow (communications wire), red to red (12V power wire), and black to black (ground wire) terminals from the remote controller to the indoor unit terminal blocks.

Figure 20: AKB74955602 Wireless Handheld Remote Controller.

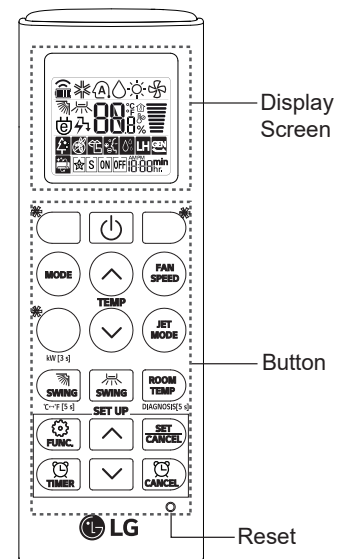

ELECTRICAL CONNECTIONS

Wired Controller Placement

Wired controllers include a sensor to detect room temperature. To maintain comfort levels in the conditioned space, the wired controller must be installed in a location away from direct sunlight, high humidity, and where it could be directly exposed to cold air. Controller must be installed four (4) to five (5) feet above the floor where its LED display can be read easily, in an area with good air circulation, and where it can detect an average room temperature.

⊘ Do not install the wired controller near or in:

- Drafts or dead spots behind doors and in corners.
- Hot or cold air from ducts.
- Radiant heat from the sun or appliances.
- Concealed pipes and chimneys.
- An area where temperatures are uncontrolled, such as an outside wall.

Figure 24: Proper Location for the Wired Controller.

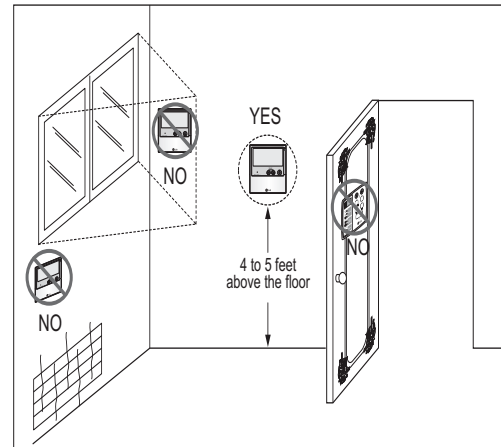

Assigning the Thermistor for Temperature Detection

Each indoor unit includes a return air thermistor assigned to sense the temperature. If a wired controller is installed, there is a choice of sensing temperature with either the indoor unit return air thermistor or the thermistor in the wired controller. It is also an option to set both thermistors to sense temperature so that indoor unit bases its operation on the first thermistor to reach the designated temperature differential.

AIR FLOW, STATIC PRESSURE, AND TEMPERATURE DISTRIBUTION

Table 10: Extended Piping Wall Mounted Outdoor Unit Air Flow Rate and Static Pressure.

Model	Air Flow Rate (CFM)	Static Pressure (in. WG)
LSU243HLV3	2,119	0.0409
LSU303HLV3, LSU363HLV3	2,295	0.0480

LSN243HLV3

Cooling

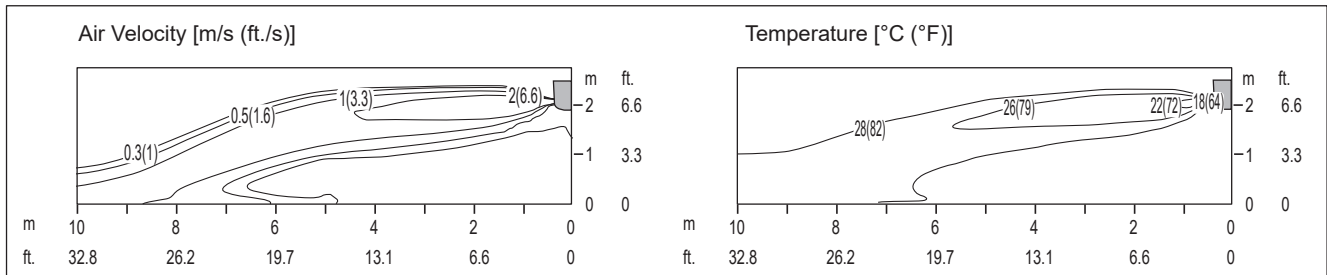

Side View

Discharge Angle : 22° (From the floor ▾)

Vertical Louver : Center

Fan Speed : Power

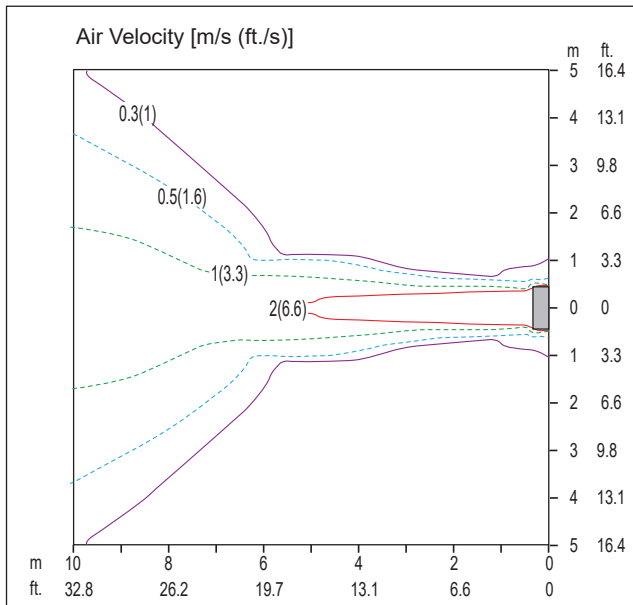

Top View

Discharge Angle : 22° (From the floor ▾)

Vertical Louver : Center

Fan Speed : Power

Air Speed 0.3 m/s (1 ft./s) Range : 20.0 m (65.6 ft.)

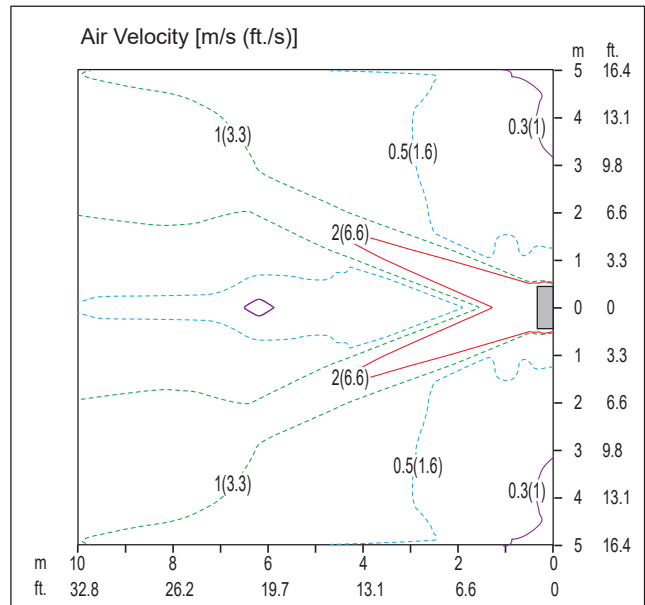

Top View

Discharge Angle : 22° (From the floor ▾)

Vertical Louver : Left & Right

Fan Speed : Power

AIR FLOW, STATIC PRESSURE, AND TEMPERATURE DISTRIBUTION

LSN243HLV3, continued.

Heating

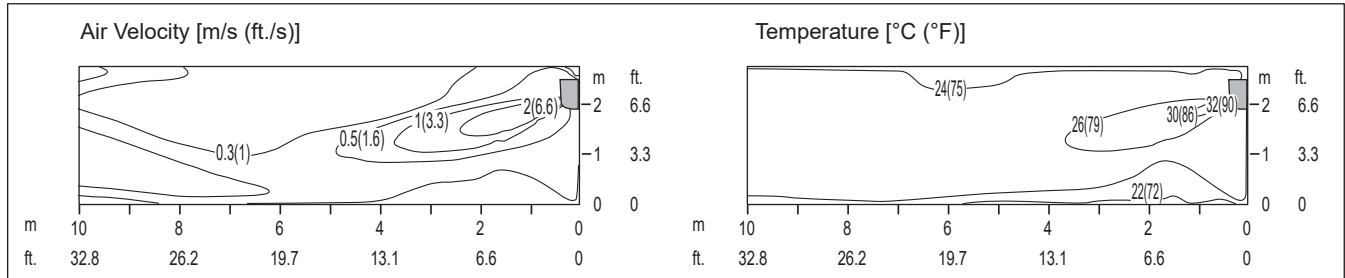

Side View

Discharge Angle : 42° (From the floor ▼)

Vertical Louver : Center

Fan Speed : Power

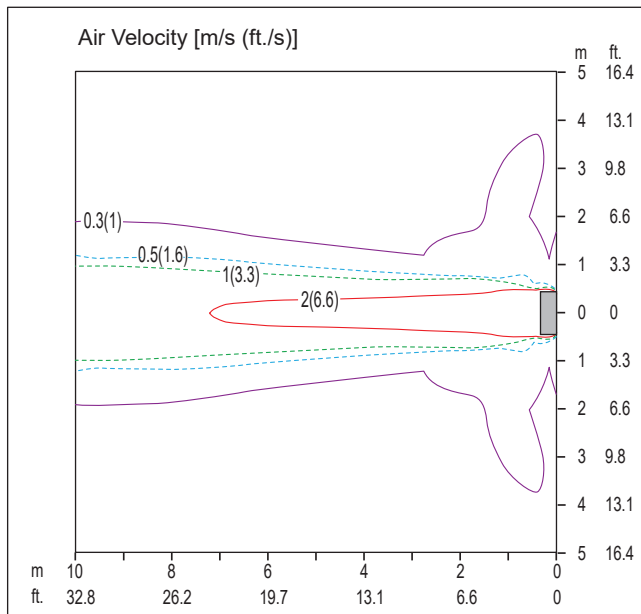

Top View

Discharge Angle : 42° (From the floor ▼)

Vertical Louver : Center

Fan Speed : Power

Air Speed 0.3 m/s (1 ft./s) Range : 20.0 m (65.6 ft.)

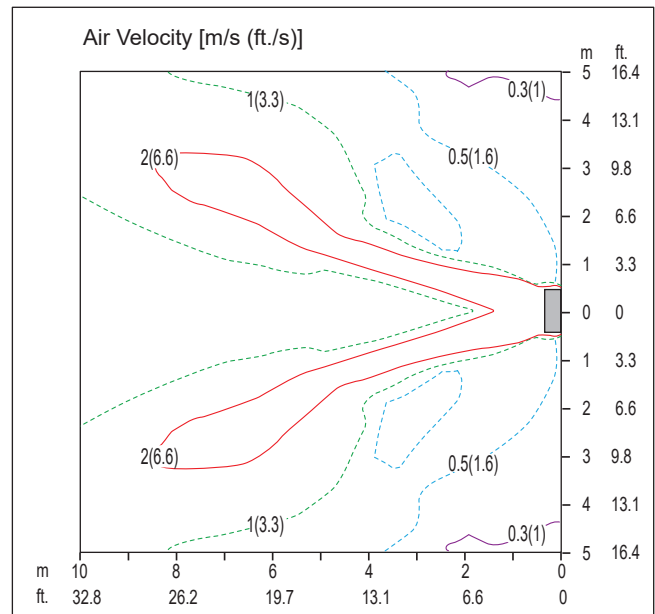

Top View

Discharge Angle : 42° (From the floor ▼)

Vertical Louver : Left & Right

Fan Speed : Power

AIR FLOW, STATIC PRESSURE, AND TEMPERATURE DISTRIBUTION

LSN303HLV3

Cooling

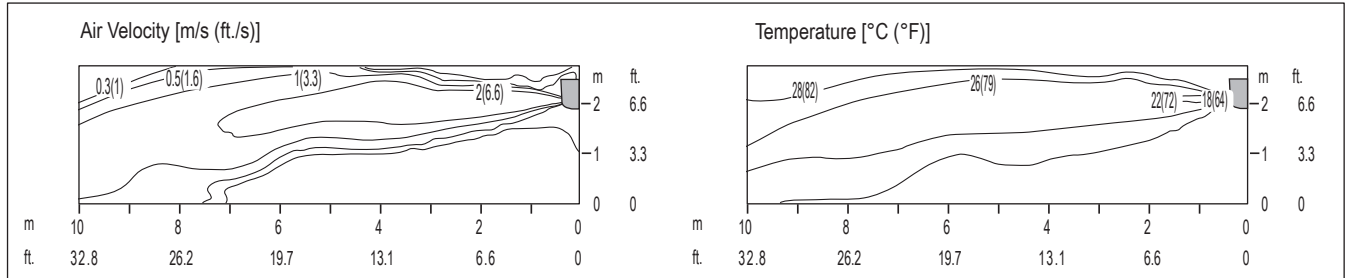

Side View

Discharge Angle : 22° (From the floor ▼)

Vertical Louver : Center

Fan Speed : Power

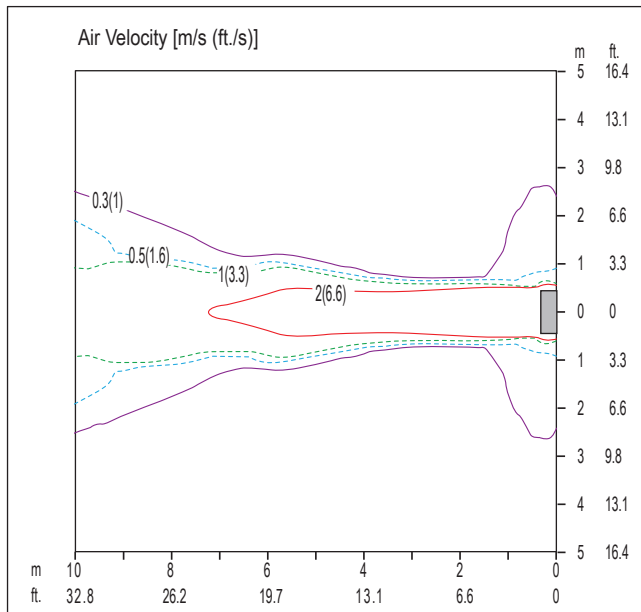

Top View

Discharge Angle : 22° (From the floor ▼)

Vertical Louver : Center

Fan Speed : Power

Air Speed 0.3 m/s (1 ft./s) Range : 20.0 m (65.6 ft.)

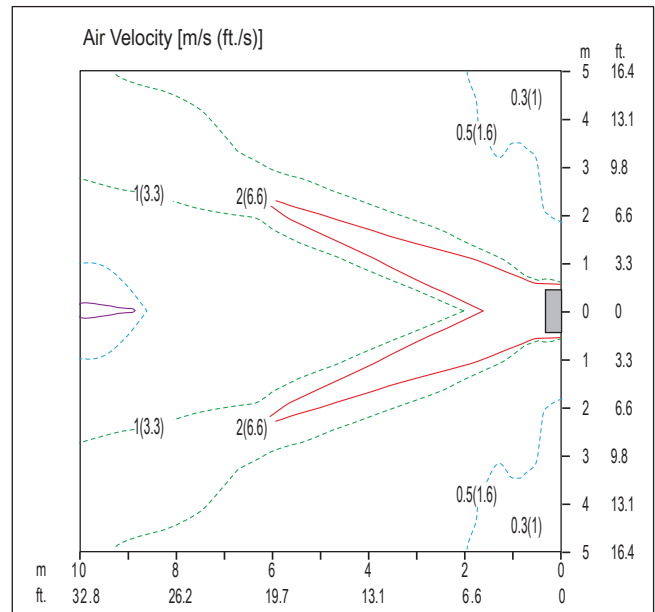

Top View

Discharge Angle : 22° (From the floor ▼)

Vertical Louver : Left & Right

Fan Speed : Power

AIR FLOW, STATIC PRESSURE, AND TEMPERATURE DISTRIBUTION

LSN303HLV3, continued.

Heating

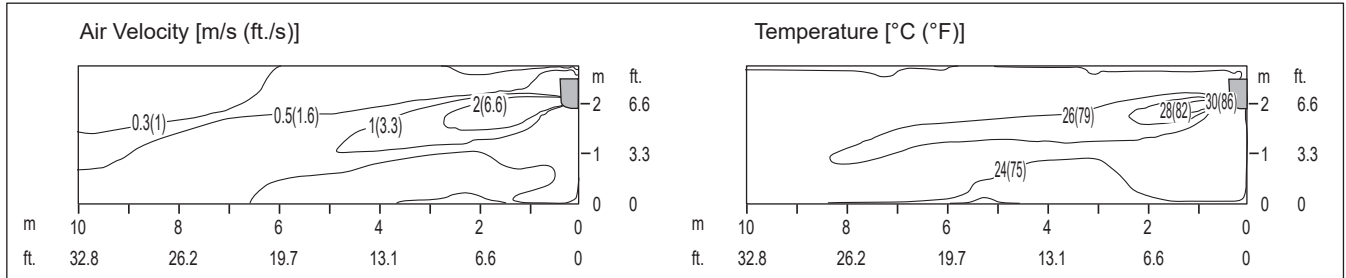

Side View

Discharge Angle : 42° (From the floor ▾)

Vertical Louver : Center

Fan Speed : Power

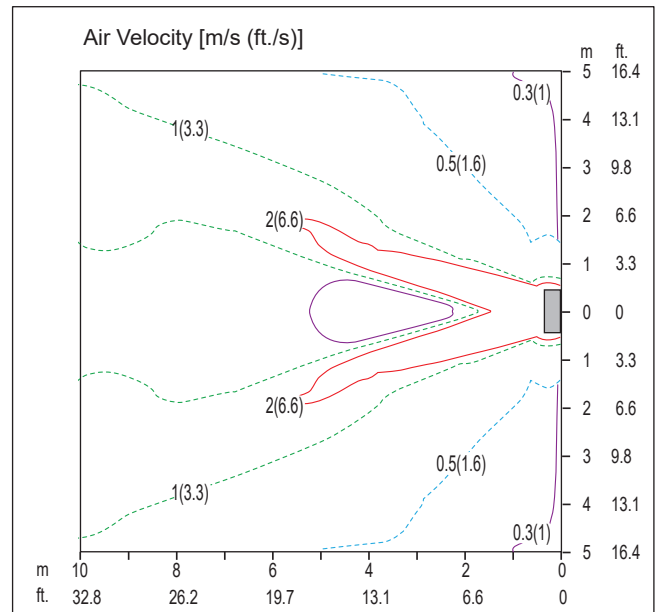
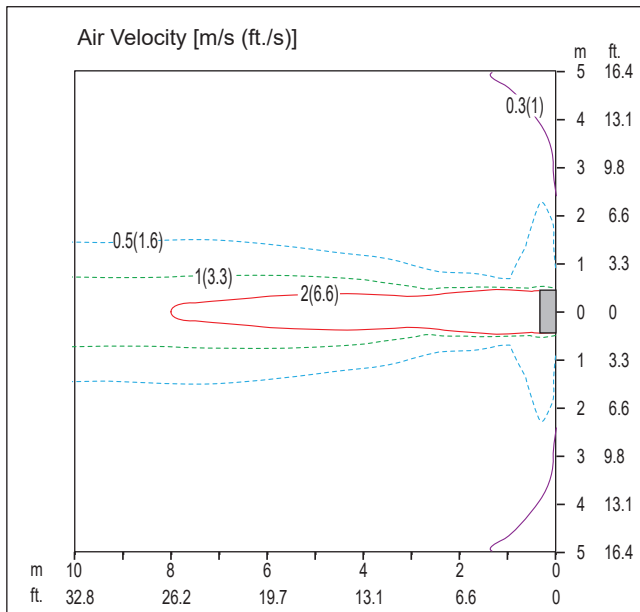

Top View

Discharge Angle : 42° (From the floor ▾)

Vertical Louver : Center

Fan Speed : Power

Air Speed 0.3 m/s (1 ft./s) Range : 20.0 m (65.6 ft.)

Top View

Discharge Angle : 42° (From the floor ▾)

Vertical Louver : Left & Right

Fan Speed : Power

AIR FLOW, STATIC PRESSURE, AND TEMPERATURE DISTRIBUTION

LSN363HLV3

Cooling

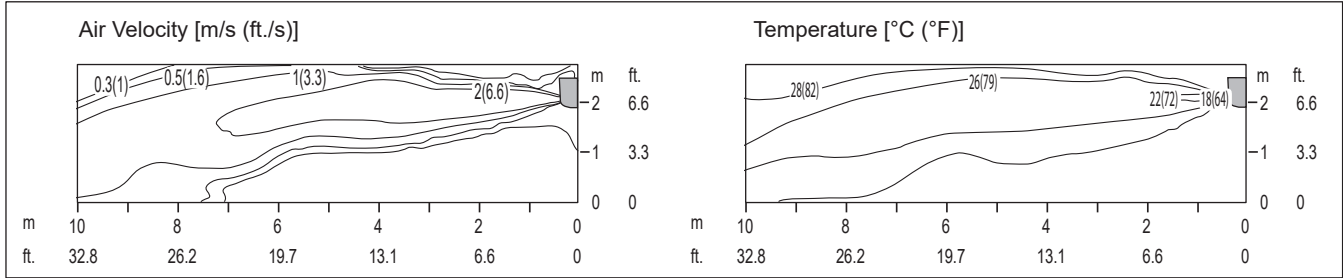

Side View

Discharge Angle : 22° (From the floor ▼)

Vertical Louver : Center

Fan Speed : Power

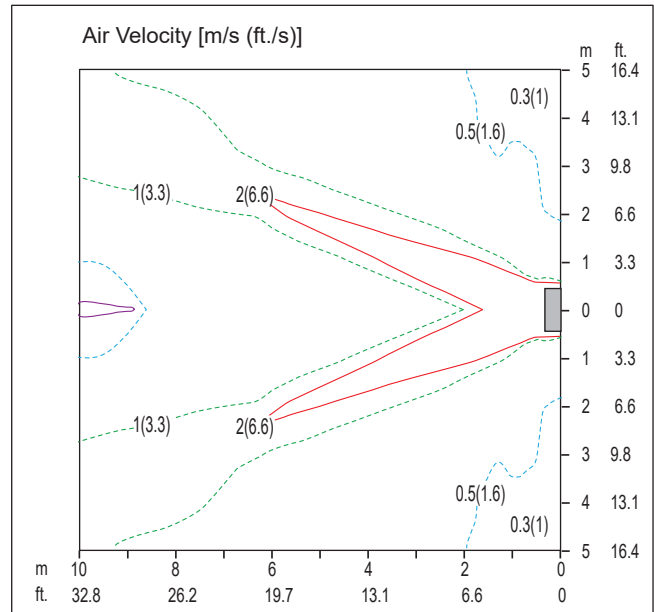
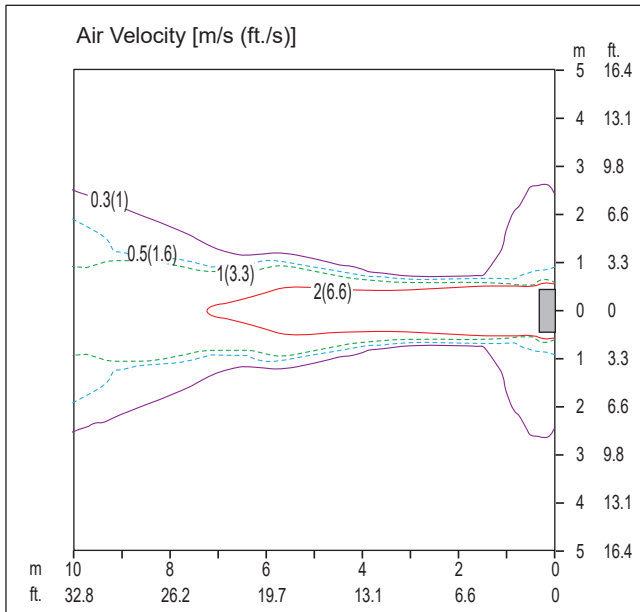

Top View

Discharge Angle : 22° (From the floor ▼)

Vertical Louver : Center

Fan Speed : Power

Air Speed 0.3 m/s (1 ft./s) Range : 20.0 m (65.6 ft.)

Top View

Discharge Angle : 22° (From the floor ▼)

Vertical Louver : Left & Right

Fan Speed : Power

AIR FLOW, STATIC PRESSURE, AND TEMPERATURE DISTRIBUTION

LSN363HLV3, continued.

Heating

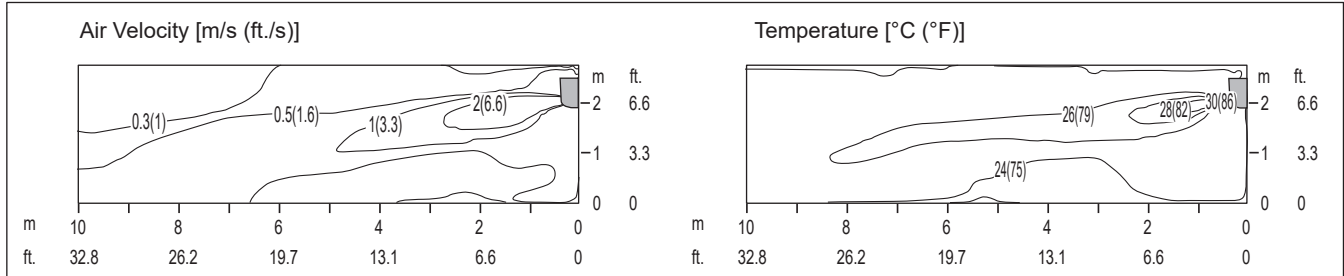

Side View

Discharge Angle : 42° (From the floor ▾)

Vertical Louver : Center

Fan Speed : Power

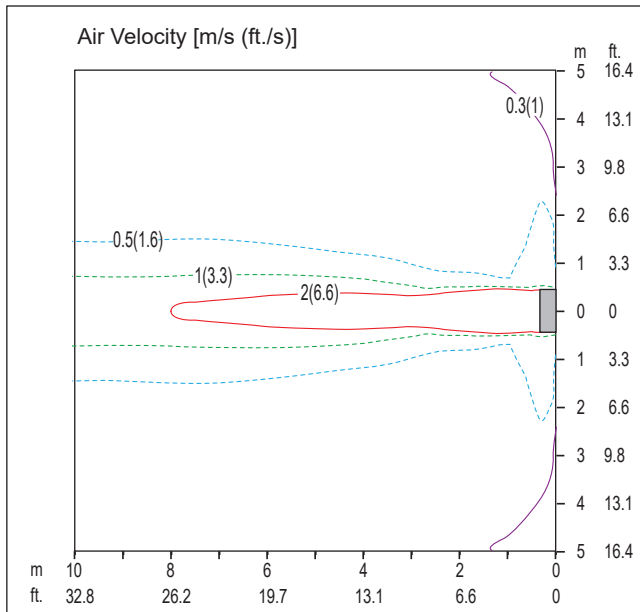

Top View

Discharge Angle : 42° (From the floor ▾)

Vertical Louver : Center

Fan Speed : Power

Air Speed 0.3 m/s (1 ft./s) Range : 20.0 m (65.6 ft.)

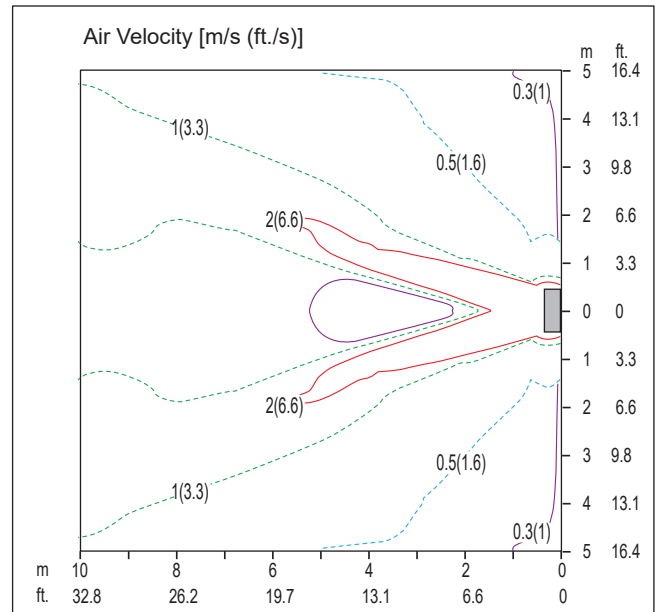

Top View

Discharge Angle : 42° (From the floor ▾)

Vertical Louver : Left & Right

Fan Speed : Power

PERFORMANCE DATA

Cooling Capacity Data on page 35

Maximum Cooling Capacity Data on page 37

Heating Capacity Data on page 39

Maximum Heating Capacity on page 41

Equipment Selection Procedure on page 43

PERFORMANCE DATA

Cooling Capacity

LS243HLV3, LS303HLV3

Cooling Capacity Table for LS243HLV3 (LSU243HLV3 + LSN243HLV3)

Table 11: LSN243HLV3 / LSU243HLV3 Cooling Capacities.

Outdoor Air Temp. (°F DB)	Indoor Air Temperature (°F DB / °F WB)																				
	64 / 53			68 / 57			72 / 61			77 / 64			80 / 67			86 / 72			90 / 75		
	TC	SHC	PI	TC	SHC	PI	TC	SHC	PI	TC	SHC	PI	TC	SHC	PI	TC	SHC	PI	TC	SHC	PI
0	13.32	10.35	0.66	16.66	11.02	0.78	19.99	11.69	0.90	24.16	12.53	1.05	26.66	13.03	1.14	22.25	14.21	0.93	19.30	15.00	0.79
5	13.07	10.20	0.69	16.34	10.86	0.81	19.61	11.52	0.94	23.70	12.35	1.10	26.15	12.84	1.19	21.82	14.01	0.97	18.93	14.78	0.83
7	13.16	10.29	0.70	16.45	10.96	0.82	19.74	11.63	0.95	23.86	12.46	1.11	26.33	12.96	1.20	21.97	14.14	0.98	19.06	14.92	0.83
10	13.29	10.44	0.71	16.62	11.11	0.84	19.95	11.79	0.97	24.10	12.63	1.13	26.60	13.14	1.22	22.20	14.33	1.00	19.26	15.12	0.85
14	13.47	10.62	0.72	16.84	11.31	0.85	20.22	12.00	0.99	24.43	12.86	1.15	26.96	13.38	1.25	22.50	14.59	1.02	19.52	15.40	0.87
23	14.46	11.41	0.71	17.40	12.14	0.86	22.33	12.88	1.01	24.00	13.80	1.20	26.20	14.36	1.31	23.06	15.66	1.04	20.96	16.53	0.87
25	14.69	11.59	0.73	17.56	12.30	0.88	20.43	13.02	1.02	24.02	13.91	1.20	26.18	14.45	1.31	23.31	15.83	1.06	21.40	16.75	0.89
30	15.25	12.03	0.79	17.97	12.70	0.92	20.68	13.36	1.05	24.08	14.19	1.22	26.11	14.68	1.32	23.94	16.25	1.10	22.50	17.30	0.95
35	15.82	12.48	0.84	18.38	13.09	0.96	20.94	13.70	1.09	24.13	14.46	1.24	26.05	14.91	1.33	24.58	16.67	1.14	23.60	17.85	1.02
40	16.39	12.93	0.89	18.79	13.48	1.01	21.19	14.04	1.12	24.19	14.73	1.26	25.99	15.15	1.34	25.21	17.09	1.19	24.70	18.39	1.08
45	16.96	13.38	0.95	19.20	13.88	1.05	21.44	14.38	1.15	24.24	15.00	1.28	25.93	15.38	1.35	25.85	17.51	1.23	25.79	18.94	1.15
50	17.52	13.82	1.00	19.61	14.27	1.09	21.69	14.72	1.18	24.30	15.27	1.30	25.86	15.61	1.36	26.48	17.94	1.27	26.89	19.49	1.21
55	18.09	14.27	1.05	20.02	14.66	1.13	21.95	15.06	1.21	24.36	15.55	1.31	25.80	15.84	1.37	27.12	18.36	1.31	27.99	20.03	1.27
60	18.66	14.72	1.11	20.43	15.06	1.18	22.20	15.40	1.24	24.41	15.82	1.33	25.74	16.07	1.38	27.75	18.78	1.36	29.09	20.58	1.34
65	18.49	14.59	1.16	20.17	15.00	1.23	21.85	15.41	1.30	23.95	15.92	1.38	25.21	16.23	1.43	27.21	18.79	1.41	28.55	20.49	1.40
70	18.32	14.45	1.22	19.91	14.94	1.28	21.50	15.42	1.35	23.48	16.02	1.42	24.67	16.38	1.47	26.68	18.80	1.47	28.02	20.41	1.47
75	18.15	14.32	1.27	19.65	14.88	1.33	21.14	15.43	1.40	23.01	16.12	1.47	24.14	16.54	1.52	26.14	18.81	1.53	27.48	20.32	1.54
80	17.98	14.19	1.33	19.39	14.81	1.39	20.79	15.44	1.45	22.55	16.22	1.52	23.60	16.69	1.56	25.61	18.82	1.59	26.94	20.24	1.61
85	17.81	14.05	1.39	19.12	14.75	1.44	20.44	15.45	1.50	22.08	16.33	1.56	23.07	16.85	1.60	25.07	18.83	1.65	26.40	20.15	1.68
90	17.64	13.92	1.44	18.86	14.69	1.49	20.09	15.46	1.55	21.62	16.43	1.61	22.53	17.00	1.65	24.53	18.84	1.71	25.87	20.07	1.75
95	17.47	13.79	1.50	18.60	14.63	1.55	19.74	15.47	1.60	21.15	16.53	1.66	22.00	17.16	1.69	24.00	18.85	1.77	25.33	19.98	1.82
100	17.01	13.43	1.52	18.17	14.31	1.57	19.34	15.19	1.62	20.79	16.29	1.68	21.66	16.95	1.72	23.58	18.55	1.79	24.87	19.62	1.84
105	16.56	13.06	1.54	17.75	13.98	1.59	18.94	14.91	1.64	20.42	16.06	1.71	21.31	16.75	1.74	23.17	18.25	1.82	24.41	19.26	1.87
110	16.10	12.70	1.57	17.32	13.66	1.62	18.54	14.62	1.67	20.06	15.82	1.73	20.97	16.54	1.77	22.76	17.95	1.84	23.95	18.89	1.89
115	15.53	12.25	1.59	16.70	13.18	1.64	17.88	14.12	1.69	19.35	15.28	1.75	20.24	15.99	1.79	21.98	17.35	1.87	23.14	18.26	1.92
118	15.18	11.98	1.60	16.34	12.89	1.65	17.49	13.81	1.70	18.93	14.96	1.76	19.80	15.65	1.80	21.52	16.99	1.88	22.66	17.88	1.93

Performance Data

Cooling Capacity Table for LS303HLV3 (LSU303HLV3 + LSN303HLV3)

Table 12: LSN303HLV3 / LSU303HLV3 Cooling Capacities.

Outdoor Air Temp. (°F DB)	Indoor Air Temperature (°F DB / °F WB)																				
	64 / 53			68 / 57			72 / 61			77 / 64			80 / 67			86 / 72			90 / 75		
	TC	SHC	PI	TC	SHC	PI	TC	SHC	PI	TC	SHC	PI	TC	SHC	PI	TC	SHC	PI	TC	SHC	PI
0	18.16	14.83	1.03	22.71	15.79	1.22	27.26	16.76	1.41	32.94	17.96	1.65	36.35	18.68	1.79	30.34	20.37	1.46	26.32	21.50	1.24
5	17.82	14.62	1.08	22.28	15.57	1.28	26.74	16.52	1.47	32.31	17.70	1.72	35.66	18.41	1.87	29.75	20.08	1.53	25.82	21.19	1.30
7	17.94	14.76	1.09	22.43	15.71	1.29	26.92	16.67	1.49	32.54	17.87	1.74	35.90	18.58	1.89	29.96	20.27	1.54	26.00	21.39	1.31
10	18.12	14.96	1.11	22.66	15.93	1.31	27.20	16.90	1.51	32.87	18.11	1.77	36.27	18.84	1.92	30.27	20.54	1.57	26.26	21.68	1.33
14	18.37	15.23	1.13	22.97	16.22	1.34	27.57	17.20	1.55	33.31	18.44	1.81	36.76	19.18	1.96	30.68	20.91	1.60	26.62	22.07	1.36
23	19.72	16.35	1.12	23.72	17.41	1.35	27.72	18.47	1.58	32.73	19.79	1.88	35.73	20.58	2.05	31.44	22.45	1.64	28.58	23.70	1.36
25	20.03	16.61	1.15	23.94	17.64	1.38	27.86	18.66	1.60	32.76	19.95	1.89	35.69	20.71	2.06	31.79	22.69	1.66	29.18	24.01	1.40
30	20.80	17.25	1.23	24.50	18.20	1.44	28.21	19.15	1.65	32.83	20.34	1.92	35.61	21.05	2.07	32.65	23.30	1.73	30.68	24.80	1.50
35	21.58	17.89	1.32	25.06	18.76	1.51	28.55	19.64	1.70	32.91	20.73	1.95	35.52	21.38	2.09	33.52	23.90	1.79	32.18	25.58	1.60
40	22.35	18.53	1.40	25.62	19.33	1.58	28.89	20.12	1.75	32.98	21.12	1.97	35.44	21.71	2.11	34.38	24.50	1.86	33.68	26.37	1.70
45	23.12	19.18	1.48	26.18	19.89	1.64	29.24	20.61	1.80	33.06	21.51	2.00	35.35	22.04	2.12	35.25	25.11	1.93	35.17	27.15	1.80
50	23.90	19.82	1.57	26.74	20.46	1.71	29.58	21.10	1.85	33.14	21.90	2.03	35.27	22.38	2.14	36.11	25.71	1.99	36.67	27.93	1.90
55	24.67	20.46	1.65	27.30	21.02	1.78	29.93	21.58	1.90	33.21	22.29	2.06	35.18	22.71	2.16	36.98	26.31	2.06	38.17	28.72	2.00
60	25.45	21.10	1.73	27.86	21.59	1.84	30.27	22.07	1.95	33.29	22.68	2.09	35.10	23.04	2.17	37.84	26.92	2.13	39.67	29.50	2.10
65	25.21	20.91	1.82	27.50	21.50	1.93	29.79	22.09	2.03	32.65	22.82	2.16	34.37	23.26	2.24	37.11	26.93	2.22	38.94	29.38	2.20
70	24.98	20.72	1.91	27.15	21.41	2.01	29.31	22.10	2.11	32.02	22.97	2.24	33.64	23.49	2.31	36.38	26.95	2.31	38.20	29.26	2.31
75	24.75	20.53	2.00	26.79	21.32	2.09	28.83	22.12	2.19	31.38	23.11	2.31	32.91	23.71	2.38	35.65	26.97	2.40	37.47	29.14	2.42
80	24.52	20.34	2.09	26.44	21.24	2.18	28.35	22.14	2.27	30.75	23.26	2.38	32.19	23.93	2.45	34.92	26.98	2.50	36.74	29.01	2.53
85	24.29	20.15	2.18	26.08	21.15	2.26	27.87	22.15	2.35	30.11	23.40	2.45	31.46	24.15	2.52	34.19	27.00	2.59	36.01	28.89	2.64
90	24.05	19.96	2.26	25.72	21.06	2.35	27.39	22.17	2.43	29.48	23.55	2.53	30.73	24.38	2.59	33.46	27.01	2.68	35.27	28.77	2.74
95	23.82	19.77	2.35	25.37	20.98	2.43	26.91	22.18	2.50	28.84	23.69	2.60	30.00	24.60	2.66	32.72	27.03	2.77	34.54	28.65	2.85
100	23.20	19.25	2.39	24.78	20.51	2.47	26.37	21.78	2.54	28.34	23.36	2.64	29.53	24.30	2.70	32.16	26.60	2.81	33.91	28.13	2.89
105	22.58	18.73	2.42	24.20	20.05	2.50	25.82	21.37	2.58	27.85	23.02	2.68	29.06	24.01	2.74	31.60	26.17	2.85	33.29	27.61	2.93
110	21.95	18.21	2.46	23.61	19.58	2.54	25.28	20.96	2.62	27.35	22.68	2.72	28.60	23.71	2.78	31.03	25.74	2.89	32.66	27.09	2.97
115	21.17	17.56	2.49	22.78	18.90	2.57	24.38	20.24	2.65	26.39	21.91	2.74	27.60	22.92	2.80	29.98	24.87	2.93	31.56	26.17	3.01
118	20.70	17.17	2.50	22.28	18.49	2.58	23.85	19.80	2.66	25.82	21.45	2.76	27.00	22.44	2.82	29.34	24.35	2.95	30.90	25.63	3.03

</

PERFORMANCE DATA

Cooling Capacity

LS363HLV3

Cooling Capacity Table for LS363HLV3 (LSU363HLV3 + LSN363HLV3)

Table 13: LSN363HLV3 / LSU363HLV3 Cooling Capacities.

Outdoor Air Temp. (°F DB)	Indoor Air Temperature (°F DB / °F WB)																				
	64 / 53			68 / 57			72 / 61			77 / 64			80 / 67			86 / 72			90 / 75		
	TC	SHC	PI	TC	SHC	PI	TC	SHC	PI	TC	SHC	PI	TC	SHC	PI	TC	SHC	PI	TC	SHC	PI
0	19.98	15.52	1.28	24.98	16.53	1.52	29.99	17.53	1.75	36.24	18.79	2.05	39.99	19.54	2.22	33.37	21.31	1.81	28.95	22.49	1.54
5	19.60	15.30	1.34	24.50	16.29	1.59	29.41	17.28	1.83	35.54	18.52	2.14	39.23	19.27	2.33	32.73	21.01	1.90	28.40	22.17	1.61
7	19.73	15.44	1.36	24.67	16.44	1.60	29.61	17.44	1.85	35.79	18.69	2.16	39.50	19.44	2.35	32.96	21.20	1.92	28.60	22.38	1.63
10	19.94	15.65	1.38	24.93	16.67	1.63	29.92	17.68	1.88	36.16	18.95	2.20	39.90	19.71	2.39	33.29	21.50	1.95	28.89	22.69	1.65
14	20.21	15.93	1.41	25.26	16.97	1.66	30.32	18.00	1.92	36.65	19.29	2.24	40.44	20.07	2.44	33.74	21.88	1.99	29.28	23.09	1.69
23	21.69	17.11	1.39	26.09	18.22	1.68	30.50	19.32	1.97	36.00	20.71	2.33	39.30	21.54	2.55	34.58	23.49	2.03	31.44	24.80	1.69
25	22.03	17.38	1.43	26.34	18.45	1.71	30.65	19.53	1.99	36.03	20.87	2.35	39.26	21.67	2.56	34.96	23.75	2.07	32.10	25.13	1.74
30	22.88	18.05	1.53	26.95	19.04	1.79	31.03	20.04	2.06	36.12	21.28	2.38	39.17	22.02	2.58	35.92	24.38	2.15	33.75	25.95	1.86
35	23.73	18.72	1.64	27.57	19.63	1.88	31.40	20.55	2.12	36.20	21.69	2.42	39.08	22.37	2.60	36.87	25.01	2.23	35.40	26.77	1.99
40	24.58	19.39	1.74	28.18	20.22	1.96	31.78	21.06	2.18	36.28	22.09	2.45	38.98	22.72	2.62	37.82	25.64	2.31	37.04	27.59	2.11
45	25.44	20.07	1.84	28.80	20.82	2.04	32.16	21.57	2.24	36.37	22.50	2.49	38.89	23.07	2.64	38.77	26.27	2.40	38.69	28.41	2.23
50	26.29	20.74	1.95	29.41	21.41	2.13	32.54	22.07	2.30	36.45	22.91	2.53	38.80	23.41	2.66	39.72	26.90	2.48	40.34	29.23	2.36
55	27.14	21.41	2.05	30.03	22.00	2.21	32.92	22.58	2.37	36.53	23.32	2.56	38.70	23.76	2.68	40.67	27.53	2.56	41.99	30.05	2.48
60	27.99	22.08	2.16	30.65	22.59	2.29	33.30	23.09	2.43	36.62	23.73	2.60	38.61	24.11	2.70	41.63	28.17	2.64	43.64	30.87	2.61
65	27.74	21.88	2.27	30.25	22.50	2.40	32.77	23.11	2.53	35.92	23.88	2.69	37.81	24.34	2.79	40.82	28.18	2.76	42.83	30.74	2.74
70	27.48	21.68	2.38	29.86	22.40	2.50	32.24	23.13	2.62	35.22	24.03	2.78	37.01	24.57	2.87	40.02	28.20	2.87	42.02	30.61	2.87
75	27.23	21.48	2.49	29.47	22.31	2.60	31.72	23.14	2.72	34.52	24.18	2.87	36.21	24.81	2.96	39.21	28.21	2.99	41.22	30.49	3.01
80	26.97	21.28	2.60	29.08	22.22	2.71	31.19	23.16	2.82	33.82	24.34	2.96	35.40	25.04	3.04	38.41	28.23	3.10	40.41	30.36	3.14
85	26.72	21.08	2.71	28.69	22.13	2.81	30.66	23.18	2.92	33.12	24.49	3.05	34.60	25.27	3.13	37.61	28.25	3.22	39.61	30.23	3.28
90	26.46	20.88	2.82	28.30	22.04	2.91	30.13	23.19	3.01	32.42	24.64	3.14	33.80	25.51	3.21	36.80	28.26	3.33	38.80	30.10	3.41
95	26.21	20.68	2.93	27.90	21.95	3.02	29.60	23.21	3.11	31.73	24.79	3.23	33.00	25.74	3.30	36.00	28.28	3.45	38.00	29.97	3.54
100	25.52	20.14	2.97	27.26	21.46	3.06	29.00	22.79	3.16	31.18	24.44	3.28	32.49	25.43	3.35	35.38	27.83	3.50	37.31	29.43	3.59
105	24.84	19.60	3.01	26.62	20.98	3.11	28.40	22.36	3.21	30.63	24.09	3.33	31.97	25.12	3.40	34.76	27.38	3.55	36.62	28.89	3.64
110	24.15	19.05	3.06	25.98	20.49	3.15	27.80	21.93	3.25	30.09	23.73	3.38	31.46	24.81	3.45	34.14	26.93	3.60	35.93	28.34	3.69
115	23.29	18.37	3.09	25.06	19.77	3.19	26.82	21.17	3.29	29.03	22.93	3.41	30.36	23.98	3.49	32.97	26.02	3.64	34.72	27.39	3.74
118	22.77	17.96	3.11	24.50	19.34	3.21	26.24	20.72	3.31	28.40	22.44	3.43	29.70	23.48	3.51	32.27	25.48	3.66	33.99	26.81	3.77

DB: Dry Bulb Temperature (°F) WB: Wet Bulb Temperature (°F) TC: Total Capacity (kBtu/h)
 SHC: Sensible Capacity (kBtu/h) PI: Power Input (kW) (includes compressor, indoor fan motor and outdoor fan motor)

1. All capacities are net, evaporator fan motor heat is deducted.
2. Low Ambient Wind Baffle Kit (sold separately) allows operation down to 0°F.

3. Direct interpolation is permissible. ⚠ Do not extrapolate.

Capacity as rated: 0 ft. above sea level with 24.6 ft. of refrigerant piping. 0 ft. level difference between outdoor and indoor units.

Cooling capacity rating obtained with air entering the indoor unit at 80°F dry bulb (DB) and 67°F wet bulb (WB), and outdoor ambient conditions of 95°F dry bulb (DB) and 75°F wet bulb (WB).

PERFORMANCE DATA

Maximum Cooling Capacity

LS243HLV3, LS303HLV3

Max. Cooling Capacity Table for LS243HLV3 (LSU243HLV3 + LSN243HLV3)

Table 14: LSN243HLV3 / LSU243HLV3 Maximum Cooling Capacities.

Outdoor Air Temp. (°F DB)	Indoor Air Temperature (°F DB / °F WB)																				
	64 / 53			68 / 57			72 / 61			77 / 64			80 / 67			86 / 72			90 / 75		
	TC	SHC	PI	TC	SHC	PI	TC	SHC	PI	TC	SHC	PI	TC	SHC	PI	TC	SHC	PI	TC	SHC	PI
0	13.43	11.52	1.31	17.34	14.22	1.34	21.25	17.44	1.38	26.14	21.46	1.52	29.08	22.85	1.54	31.41	24.98	1.45	32.96	26.75	1.27
5	13.49	11.78	1.34	17.42	14.52	1.38	21.35	17.77	1.44	26.27	21.84	1.60	29.22	23.26	1.63	31.55	25.39	1.52	33.11	27.16	1.33
7	13.59	11.85	1.34	17.54	14.60	1.39	21.50	17.87	1.45	26.45	21.95	1.62	29.41	23.38	1.65	31.77	25.51	1.54	33.34	27.28	1.35
10	13.73	11.96	1.35	17.73	14.73	1.40	21.72	18.02	1.47	26.72	22.12	1.64	29.71	23.55	1.68	32.09	25.69	1.56	33.67	27.46	1.37
14	13.92	12.11	1.36	17.97	14.90	1.42	22.02	18.21	1.50	27.07	22.34	1.68	30.11	23.79	1.72	32.52	25.93	1.59	34.12	27.69	1.39
23	12.60	10.96	1.43	16.98	13.95	1.50	21.36	17.46	1.58	26.84	21.84	1.77	30.13	23.44	1.81	32.39	25.72	1.70	33.90	27.58	1.51
25	12.59	10.95	1.43	16.97	13.94	1.50	21.36	17.45	1.58	26.84	21.83	1.77	30.13	23.43	1.82	32.39	25.71	1.72	33.90	27.57	1.54
30	12.57	10.93	1.44	16.96	13.92	1.51	21.35	17.43	1.60	26.84	21.82	1.79	30.14	23.42	1.84	32.40	25.69	1.78	33.91	27.54	1.63
35	12.55	10.90	1.44	16.95	13.90	1.52	21.34	17.42	1.61	26.84	21.81	1.81	30.14	23.41	1.86	32.40	25.67	1.84	33.91	27.52	1.72
40	12.53	10.88	1.45	16.93	13.88	1.53	21.34	17.40	1.62	26.84	21.79	1.83	30.14	23.40	1.88	32.41	25.65	1.90	33.92	27.49	1.80
45	12.51	10.86	1.46	16.92	13.86	1.54	21.33	17.38	1.64	26.84	21.78	1.84	30.15	23.39	1.90	32.42	25.63	1.96	33.93	27.47	1.89
50	12.49	10.83	1.46	16.90	13.84	1.55	21.32	17.36	1.65	26.84	21.77	1.86	30.15	23.38	1.92	32.42	25.61	2.02	33.93	27.44	1.98
55	12.46	10.81	1.47	16.89	13.82	1.56	21.31	17.35	1.66	26.84	21.75	1.88	30.16	23.37	1.94	32.43	25.59	2.08	33.94	27.41	2.06
60	12.44	10.78	1.48	16.87	13.80	1.57	21.30	17.33	1.67	26.84	21.74	1.89	30.16	23.36	1.96	32.43	25.57	2.14	33.95	27.39	2.15
65	12.24	10.61	1.51	16.71	13.66	1.63	21.19	17.22	1.78	26.78	21.68	2.04	30.14	23.32	2.13	32.45	25.57	2.32	34.00	27.41	2.33
70	12.03	10.44	1.54	16.55	13.52	1.70	21.07	17.12	1.88	26.72	21.62	2.19	30.12	23.29	2.30	32.47	25.57	2.49	34.05	27.43	2.51
75	11.82	10.26	1.57	16.39	13.38	1.77	20.96	17.02	1.98	26.67	21.56	2.33	30.09	23.25	2.48	32.50	25.57	2.67	34.10	27.46	2.69
80	11.61	10.09	1.61	16.23	13.24	1.84	20.84	16.91	2.09	26.61	21.50	2.48	30.07	23.22	2.65	32.52	25.57	2.85	34.15	27.48	2.87
85	11.40	9.92	1.64	16.06	13.11	1.91	20.72	16.81	2.19	26.55	21.44	2.63	30.05	23.18	2.82	32.54	25.57	3.02	34.20	27.50	3.04
90	11.19	9.75	1.67	15.90	12.97	1.97	20.61	16.70	2.29	26.49	21.37	2.77	30.02	23.15	3.00	32.56	25.57	3.20	34.25	27.52	3.22
95	10.99	9.57	1.70	15.74	12.83	2.04	20.49	16.60	2.39	26.44	21.31	2.92	30.00	23.11	3.17	32.58	25.57	3.38	34.30	27.55	3.40
100	10.29	8.93	1.81	14.94	12.24	2.13	19.60	16.07	2.46	25.41	20.86	2.96	28.91	22.70	3.19	31.25	25.13	3.39	32.81	27.09	3.40
105	9.59	8.29	1.92	14.14	11.66	2.21	18.70	15.54	2.52	24.39	20.40	3.00	27.81	22.28	3.21	29.92	24.69	3.39	31.33	26.63	3.40
110	8.89	7.64	2.02	13.34	11.07	2.29	17.80	15.01	2.59	23.37	19.94	3.03	26.71	21.87	3.23	28.59	24.25	3.40	29.85	26.18	3.40
115	8.28	7.18	2.09	11.61	9.93	2.20	14.94	13.18	2.32	19.10	17.25	2.56	21.59	18.67	2.64	23.06	20.97	2.83	24.03	22.84	2.85
118	7.91	6.91	2.13	10.56	9.24	2.14	13.22	12.08	2.16	16.53	15.64	2.28	18.52	16.75	2.28	19.74	19.00	2.49	20.55	20.84	2.52

Performance Data

Max. Cooling Capacity Table for LS303HLV3 (LSU303HLV3 + LSN303HLV3)

Table 15: LSN303HLV3 / LSU303HLV3 Maximum Cooling Capacities.

Outdoor Air Temp. (°F DB)	Indoor Air Temperature (°F DB / °F WB)																				
	64 / 53			68 / 57			72 / 61			77 / 64			80 / 67			86 / 72			90 / 75		
	TC	SHC	PI	TC	SHC	PI	TC	SHC	PI	TC	SHC	PI	TC	SHC	PI	TC	SHC	PI	TC	SHC	PI
0	15.85	14.09	1.74	19.41	16.80	1.77	22.96	19.67	1.81	27.41	22.32	1.95	30.08	23.71	1.97	32.20	27.21	1.88	33.61	28.98	1.70
5	15.91	14.35	1.77	19.48	17.09	1.81	23.06	20.00	1.87	27.53	22.70	2.03	30.21	24.12	2.06	32.33	27.62	1.95	33.75	29.39	1.76
7	15.99	14.42	1.77	19.59	17.18	1.82	23.19	20.10	1.88	27.69	22.81	2.05	30.39	24.23	2.08	32.53	27.74	1.97	33.95	29.51	1.78
10	16.12	14.54	1.78	19.76	17.31	1.83	23.39	20.25	1.90	27.93	22.98	2.07	30.66	24.41	2.11	32.82	27.92	1.99	34.26	29.69	1.80
14	16.30	14.68	1.79	19.98	17.48	1.85	23.66	20.44	1.93	28.26	23.20	2.11	31.02	24.65	2.15	33.21	28.16	2.02	34.67	29.93	1.82
23	15.09	13.54	1.86	19.08	16.53	1.93	23.07	19.69	2.01	28.05	22.70	2.20	31.04	24.29	2.24	33.09	27.95	2.13	34.46	29.81	1.94
25	15.09	13.53	1.86	19.07	16.52	1.93	23.06	19.68	2.01	28.05	22.69	2.20	31.04	24.29	2.25	33.09	27.94	2.15	34.46	29.80	1.97
30	15.07	13.50	1.87	19.06	16.50	1.94	23.05	19.66	2.03	28.05	22.68	2.22	31.04	24.28	2.27	33.10	27.92	2.21	34.47	29.77	2.06
35	15.05	13.48	1.87	19.05	16.48	1.95	23.05	19.65	2.04	28.05	22.66	2.24	31.05	24.27	2.29	33.10	27.90	2.27	34.48	29.75	2.15
40	15.03	13.45	1.88	19.03	16.46	1.96	23.04	19.63	2.05	28.05	22.65	2.26	31.05	24.26	2.31	33.11	27.88	2.33	34.48	29.72	2.23
45	15.00	13.43	1.89	19.01	16.43	1.97	23.02	19.61	2.07	28.03	22.64	2.27	31.04	24.25	2.33	33.10	27.86	2.39	34.48	29.70	2.32
50	14.99	13.41	1.89	19.00	16.41	1.98	23.02	19.59	2.08	28.03	22.62	2.29	31.05	24.24	2.35	33.11	27.84	2.45	34.48	29.67	2.41
55	14.97	13.38	1.90	18.99	16.39	1.99	23.01	19.58	2.09	28.03	22.61	2.31	31.05	24.23	2.37	33.11	27.82	2.51	34.49	29.64	2.49
60	14.95	13.36	1.90	18.97	16.37	2.00	23.00	19.56	2.10	28.03	22.60	2.32	31.05	24.22	2.39	33.12	27.80	2.57	34.49	29.62	2.58
65	14.76	13.18	1.94	18.83	16.23	2.06	22.90	19.45	2.21	27.98	22.54	2.47	31.03	24.18	2.56	33.14	27.80	2.75	34.54	29.64	2.76
70	14.57	13.01	1.97	18.68	16.10	2.13	22.79	19.35	2.31	27.93	22.48	2.62	31.01	24.15	2.73	33.16	27.80	2.92	34.59	29.66	2.94
75	14.38	12.84	2.00	18.54	15.96	2.20	22.69	19.25	2.41	27.89	22.42	2.76	31.00	24.11	2.91	33.19	27.80	3.10	34.64	29.69	3.12
80	14.46	12.67	2.04	18.74	15.82	2.27	23.01	19.14	2.52	28.36	22.35	2.91	31.56	24.08	3.08	33.83	27.80	3.28	35.34	29.71	3.30
85	14.68	12.49	2.07	19.12	15.68	2.34	23.57	19.04	2.62	29.12	22.29	3.06	32.45	24.04	3.25	34.83	27.80	3.45	36.41	29.73	3.47
90	14.92	12.32	2.10	19.54	15.54	2.40	24.16	18.93	2.72	29.94	22.23	3.20	33.40	24.00	3.43	35.89	27.80	3.63	37.55	29.75	3.65
95	14.99	12.15	2.13	19.74	15.40	2.47	24.49	18.83	2.82	30.44	22.17	3.35	34.00	23.97	3.60	36.58	27.80	3.81	38.30	29.78	3.83
100	14.29	11.50	2.24	18.94	14.82	2.56	23.60	18.30	2.89	29.41	21.71	3.39	32.90	23.55	3.62	35.25	27.36	3.82	36.81	29.32	3.83
105	13.59	10.86	2.35	18.14	14.23	2.64	22.70	17.77	2.95	28.39	21.25	3.43	31.81	23.14	3.64	33.92	26.92	3.82	35.33	28.86	3.83
110	12.89	10.22	2.45	17.34	13.64	2.72	21.80	17.24	3.02	27.37	20.80	3.46	30.71	22.72	3.66	32.59	26.48	3.83	33.84	28.41	3.83
115	12.28	9.76	2.52	15.61	12.50	2.63	18.93	15.41	2.75	23.10	18.11	2.99	25.59	19.53	3.07	27.06	23.20	3.26	28.03	25.07	3.28
118	11.91	9.48	2.56	14.56	11.81	2.57	17.22	14.32	2.59	20.53	16.50	2.71	22.52	17.61	2.71	23.73	21.23	2.92	24.54	23.07	2.95

PERFORMANCE DATA

Maximum Cooling Capacity

LS363HLV3

Max. Cooling Capacity Table for LS363HLV3 (LSU363HLV3 + LSN363HLV3)

Table 16: LSN363HLV3 / LSU363HLV3 Maximum Cooling Capacities.

Outdoor Air Temp. (°F DB)	Indoor Air Temperature (°F DB / °F WB)																				
	64 / 53			68 / 57			72 / 61			77 / 64			80 / 67			86 / 72			90 / 75		
	TC	SHC	PI	TC	SHC	PI	TC	SHC	PI	TC	SHC	PI	TC	SHC	PI	TC	SHC	PI	TC	SHC	PI
0	17.43	15.30	2.16	21.34	18.17	2.19	25.25	20.87	2.23	30.14	24.38	2.37	33.08	25.77	2.39	35.40	28.41	2.30	36.96	30.18	2.12
5	17.49	15.55	2.19	21.42	18.46	2.23	25.35	21.21	2.29	30.27	24.76	2.45	33.22	26.17	2.48	35.55	28.82	2.37	37.11	30.59	2.19
7	17.59	15.63	2.19	21.54	18.55	2.24	25.50	21.30	2.30	30.45	24.87	2.47	33.41	26.29	2.50	35.77	28.94	2.39	37.33	30.71	2.20
10	17.73	15.74	2.20	21.73	18.68	2.25	25.72	21.45	2.32	30.72	25.04	2.49	33.71	26.47	2.53	36.09	29.12	2.41	37.67	30.89	2.22
14	17.92	15.89	2.21	21.97	18.85	2.27	26.02	21.64	2.35	31.07	25.26	2.53	34.11	26.71	2.57	36.52	29.36	2.44	38.12	31.13	2.25
23	16.60	14.74	2.28	20.98	17.90	2.35	25.36	20.89	2.43	30.84	24.75	2.62	34.13	26.35	2.66	36.39	29.15	2.55	37.90	31.01	2.36
25	16.59	14.73	2.28	20.97	17.89	2.35	25.36	20.88	2.44	30.84	24.75	2.63	34.13	26.35	2.67	36.39	29.14	2.57	37.90	31.00	2.39
30	16.57	14.70	2.29	20.96	17.87	2.36	25.35	20.86	2.45	30.84	24.74	2.64	34.14	26.34	2.69	36.40	29.12	2.63	37.91	30.97	2.48
35	16.55	14.68	2.30	20.95	17.85	2.37	25.34	20.85	2.46	30.84	24.72	2.66	34.14	26.33	2.71	36.40	29.10	2.69	37.91	30.95	2.57
40	16.53	14.66	2.30	20.93	17.83	2.38	25.34	20.83	2.47	30.84	24.71	2.68	34.14	26.32	2.73	36.41	29.08	2.75	37.92	30.92	2.65
45	16.51	14.63	2.31	20.92	17.81	2.39	25.33	20.81	2.49	30.84	24.70	2.69	34.15	26.31	2.75	36.41	29.06	2.81	37.93	30.90	2.74
50	16.48	14.61	2.31	20.90	17.79	2.40	25.32	20.79	2.50	30.84	24.68	2.71	34.15	26.30	2.77	36.42	29.04	2.87	37.93	30.87	2.83
55	16.46	14.58	2.32	20.89	17.77	2.41	25.31	20.78	2.51	30.84	24.67	2.73	34.16	26.29	2.79	36.43	29.02	2.93	37.94	30.85	2.91
60	16.44	14.56	2.33	20.87	17.74	2.42	25.30	20.76	2.53	30.84	24.66	2.74	34.16	26.27	2.81	36.43	29.00	2.99	37.95	30.82	3.00
65	16.24	14.39	2.36	20.71	17.61	2.49	25.19	20.66	2.63	30.78	24.60	2.89	34.14	26.24	2.98	36.45	29.00	3.17	38.00	30.84	3.18
70	16.03	14.21	2.39	20.55	17.47	2.55	25.07	20.55	2.73	30.72	24.54	3.04	34.12	26.20	3.15	36.47	29.00	3.34	38.05	30.87	3.36
75	15.82	14.04	2.42	20.39	17.33	2.62	24.96	20.45	2.83	30.67	24.47	3.18	34.09	26.17	3.33	36.49	29.00	3.52	38.10	30.89	3.54
80	15.61	13.87	2.46	20.23	17.19	2.69	24.84	20.34	2.94	30.61	24.41	3.33	34.07	26.13	3.50	36.52	29.00	3.70	38.15	30.91	3.72
85	15.40	13.69	2.49	20.06	17.05	2.76	24.72	20.24	3.04	30.55	24.35	3.48	34.05	26.10	3.67	36.54	29.00	3.87	38.20	30.93	3.90
90	15.19	13.52	2.52	19.90	16.91	2.82	24.61	20.14	3.14	30.49	24.29	3.63	34.02	26.06	3.85	36.56	29.00	4.05	38.25	30.96	4.08
95	14.99	13.35	2.56	19.74	16.78	2.89	24.49	20.03	3.25	30.44	24.23	3.77	34.00	26.03	4.02	36.58	29.00	4.23	38.30	30.98	4.25
100	14.29	12.71	2.66	18.94	16.19	2.98	23.60	19.50	3.31	29.41	23.77	3.81	32.90	25.61	4.04	35.25	28.56	4.24	36.81	30.52	4.25
105	13.59	12.06	2.77	18.14	15.60	3.06	22.70	18.97	3.37	28.39	23.31	3.85	31.81	25.20	4.06	33.92	28.12	4.25	35.33	30.07	4.25
110	12.89	11.42	2.87	17.34	15.02	3.15	21.80	18.44	3.44	27.37	22.86	3.88	30.71	24.78	4.09	32.59	27.68	4.25	33.84	29.61	4.25
115	12.28	10.96	2.94	16.61	14.37	3.05	18.93	16.61	3.17	23.10	20.17	3.41	25.59	21.58	3.49	27.06	24.40	3.68	28.03	26.27	3.70
118	11.91	10.68	2.98	14.56	13.18	2.99	17.22	15.52	3.01	20.53	18.56	3.13	22.52	19.67	3.13	23.73	22.43	3.34	24.54	24.27	3.37

DB: Dry Bulb Temperature (°F) WB: Wet Bulb Temperature (°F) TC: Total Capacity (kBtu/h)
 SHC: Sensible Capacity (kBtu/h) PI: Power Input (kW) (includes compressor, indoor fan motor and outdoor fan motor)

- All capacities are net, evaporator fan motor heat is deducted.
- Low Ambient Wind Baffle Kit (sold separately) allows operation down to 0°F.

3. Direct interpolation is permissible. ⚠ Do not extrapolate.

Capacity as rated: 0 ft. above sea level with 24.6 ft. of refrigerant piping, 0 ft. level difference between outdoor and indoor units.

Cooling capacity rating obtained with air entering the indoor unit at 80°F dry bulb (DB) and 67°F wet bulb (WB), and outdoor ambient conditions of 95°F dry bulb (DB) and 75°F wet bulb (WB).

PERFORMANCE DATA

Heating Capacity LS243HLV3, LS303HLV3

Heating Capacity Table for LS243HLV3 (LSU243HLV3 + LSN243HLV3)

Table 17: LSN243HLV3 / LSU243HLV3 Heating Capacities.

Outdoor Air Temp.		Indoor Air Temperature (°F DB)													
°F DB	°F WB	60		64		68		70		72		75		86	
		TC	PI	TC	PI	TC	PI	TC	PI	TC	PI	TC	PI	TC	PI
-3	-4	13.26	1.39	12.86	1.37	12.73	1.37	12.60	1.36	12.51	1.36	12.26	1.35	11.97	1.35
0	-1	14.44	1.52	14.00	1.51	13.86	1.51	13.72	1.49	13.62	1.49	13.34	1.48	13.03	1.48
1	0	14.62	1.54	14.18	1.52	14.03	1.52	13.90	1.51	13.79	1.51	13.51	1.49	13.19	1.49
6	5	15.28	1.59	14.81	1.58	14.66	1.58	14.52	1.56	14.41	1.56	14.12	1.55	13.78	1.55
10	9	15.95	1.64	15.47	1.63	15.31	1.63	15.16	1.61	15.04	1.61	14.74	1.59	14.39	1.59
16	14	16.45	1.66	15.95	1.64	15.79	1.64	15.64	1.63	15.52	1.63	15.20	1.61	14.84	1.61
17	15	16.56	1.68	16.06	1.66	15.90	1.66	15.74	1.64	15.62	1.64	15.31	1.63	14.94	1.63
19	17	16.79	1.71	16.28	1.69	16.11	1.69	15.95	1.68	15.83	1.68	15.51	1.66	15.15	1.66
24	23	18.41	1.77	17.86	1.76	17.68	1.76	17.50	1.74	17.37	1.74	17.02	1.72	16.61	1.72
32	30	22.07	1.92	21.40	1.90	21.19	1.90	20.98	1.88	20.82	1.88	20.40	1.86	19.91	1.86
41	38	25.33	2.04	24.56	2.02	24.31	2.02	24.07	2.00	23.88	2.00	23.40	1.98	22.85	1.98
43	40	26.14	2.07	25.35	2.05	25.09	2.05	24.84	2.03	24.65	2.03	24.16	2.01	23.58	2.01
47	43	27.36	2.12	26.53	2.10	26.26	2.10	26.00	2.08	25.80	2.08	25.28	2.06	24.68	2.06
53	50	27.63	2.14	26.79	2.12	26.52	2.12	26.26	2.10	26.06	2.10	25.54	2.08	24.93	2.08
59	53	28.26	2.16	27.40	2.14	27.13	2.14	26.86	2.12	26.65	2.12	26.12	2.10	25.50	2.10
64	57	28.86	2.21	27.99	2.18	27.70	2.18	27.43	2.16	27.22	2.16	26.67	2.14	26.04	2.14
70	61	29.41	2.24	28.52	2.22	28.23	2.22	27.95	2.19	27.74	2.19	27.18	2.17	26.53	2.17
75	65	29.82	2.27	28.92	2.25	28.62	2.25	28.34	2.23	28.12	2.23	27.56	2.20	26.90	2.20

Heating Capacity Table for LS303HLV3 (LSU303HLV3 + LSN303HLV3)

Table 18: LSN303HLV3 / LSU303HLV3 Heating Capacities.

Outdoor Air Temp.		Indoor Air Temperature (°F DB)													
°F DB	°F WB	60		64		68		70		72		75		86	
		TC	PI	TC	PI	TC	PI	TC	PI	TC	PI	TC	PI	TC	PI
-3	-4	16.53	1.84	16.03	1.82	15.86	1.82	15.71	1.80	15.59	1.80	15.27	1.78	14.91	1.78
0	-1	17.99	2.02	17.45	2.00	17.27	2.00	17.10	1.98	16.97	1.98	16.63	1.96	16.23	1.96
1	0	18.22	2.04	17.67	2.02	17.49	2.02	17.32	2.00	17.18	2.00	16.84	1.98	16.44	1.98
6	5	19.04	2.11	18.46	2.09	18.27	2.09	18.09	2.07	17.95	2.07	17.59	2.05	17.18	2.05
10	9	19.87	2.18	19.27	2.15	19.08	2.15	18.89	2.13	18.74	2.13	18.37	2.11	17.93	2.11
16	14	20.50	2.20	19.88	2.18	19.68	2.18	19.48	2.16	19.34	2.16	18.95	2.13	18.50	2.13
17	15	20.64	2.22	20.02	2.20	19.81	2.20	19.62	2.18	19.47	2.18	19.08	2.16	18.62	2.16
19	17	20.92	2.27	20.29	2.24	20.08	2.24	19.88	2.22	19.73	2.22	19.33	2.20	18.87	2.20
24	23	22.95	2.35	22.25	2.33	22.03	2.33	21.81	2.30	21.64	2.30	21.21	2.28	20.70	2.28
32	30	27.51	2.54	26.67	2.51	26.40	2.51	26.14	2.49	25.94	2.49	25.42	2.46	24.82	2.46
41	38	31.56	2.70	30.60	2.68	30.29	2.68	29.99	2.65	29.76	2.65	29.17	2.63	28.47	2.63
43	40	32.57	2.75	31.59	2.72	31.27	2.72	30.96	2.69	30.72	2.69	30.10	2.67	29.39	2.67
47	43	34.09	2.81	33.06	2.78	32.72	2.78	32.40	2.75	32.15	2.75	31.51	2.73	30.76	2.73
53	50	34.43	2.84	33.39	2.81	33.05	2.81	32.72	2.78	32.47	2.78	31.82	2.75	31.07	2.75
59	53	35.22	2.87	34.15	2.84	33.80	2.84	33.47	2.81	33.21	2.81	32.55	2.78	31.77	2.78
64	57	35.97	2.92	34.88	2.89	34.52	2.89	34.18	2.86	33.92	2.86	33.24	2.84	32.45	2.84
70	61	36.65	2.96	35.54	2.93	35.18	2.93	34.83	2.91	34.56	2.91	33.87	2.88	33.06	2.88
75	65	37.16	3.01	36.03	2.98	35.67	2.98	35.32	2.95	35.05	2.95	34.34	2.92	33.53	2.92

DB: Dry Bulb Temperature (°F) WB: Wet Bulb Temperature (°F) TC: Total Capacity (kBtu/h)
PI: Power Input (kW) (includes compressor, indoor fan motor and outdoor fan motor)

1. All capacities are net, evaporator fan motor heat is deducted.
2. Direct interpolation is permissible. ⚠ Do not extrapolate.

Capacity as rated: 0 ft. above sea level with 24.6 ft. of refrigerant piping. 0 ft. level difference between outdoor and indoor units.

Heating capacity rating obtained with air entering the indoor unit at 70°F dry bulb (DB) and 60°F wet bulb (WB), and outdoor ambient conditions of 47°F dry bulb (DB) and 43°F wet bulb (WB).

PERFORMANCE DATA

Heating Capacity

LS363HLV3

Heating Capacity Table for LS363HLV3 (LSU363HLV3 + LSN363HLV3)

Table 19: LSN363HLV3 / LSU363HLV3 Heating Capacities.

Outdoor Air Temp.		Indoor Air Temperature (°F DB)													
°F DB	°F WB	60		64		68		70		72		75		86	
		TC	PI	TC	PI	TC	PI	TC	PI	TC	PI	TC	PI	TC	PI
-3	-4	17.96	2.08	17.41	2.06	17.23	2.06	17.06	2.04	16.93	2.04	16.59	2.02	16.20	2.02
0	-1	19.55	2.28	18.95	2.26	18.76	2.26	18.58	2.24	18.43	2.24	18.06	2.21	17.63	2.21
1	0	19.80	2.30	19.19	2.28	19.00	2.28	18.81	2.26	18.67	2.26	18.29	2.24	17.86	2.24
6	5	20.68	2.38	20.06	2.36	19.85	2.36	19.66	2.34	19.51	2.34	19.11	2.31	18.66	2.31
10	9	21.59	2.46	20.94	2.44	20.73	2.44	20.52	2.41	20.36	2.41	19.95	2.39	19.48	2.39
16	14	22.27	2.49	21.60	2.46	21.38	2.46	21.17	2.44	21.01	2.44	20.58	2.41	20.10	2.41
17	15	22.43	2.51	21.75	2.49	21.53	2.49	21.31	2.46	21.15	2.46	20.72	2.44	20.23	2.44
19	17	22.73	2.56	22.04	2.54	21.82	2.54	21.60	2.51	21.43	2.51	21.00	2.49	20.51	2.49
24	23	24.93	2.66	24.17	2.63	23.93	2.63	23.69	2.61	23.51	2.61	23.04	2.58	22.49	2.58
32	30	29.88	2.87	28.98	2.84	28.68	2.84	28.40	2.81	28.18	2.81	27.62	2.79	26.96	2.79
41	38	34.29	3.06	33.25	3.03	32.91	3.03	32.58	3.00	32.34	3.00	31.69	2.97	30.93	2.97
43	40	35.39	3.11	34.31	3.08	33.97	3.08	33.63	3.05	33.37	3.05	32.70	3.02	31.93	3.02
47	43	37.04	3.18	35.92	3.15	35.55	3.15	35.20	3.12	34.93	3.12	34.23	3.08	33.42	3.08
53	50	37.41	3.21	36.28	3.18	35.91	3.18	35.55	3.15	35.28	3.15	34.57	3.11	33.75	3.11
59	53	38.26	3.24	37.10	3.21	36.73	3.21	36.36	3.18	36.08	3.18	35.36	3.15	34.52	3.15
64	57	39.08	3.30	37.89	3.27	37.51	3.27	37.14	3.24	36.85	3.24	36.11	3.21	35.25	3.21
70	61	39.82	3.35	38.61	3.32	38.22	3.32	37.84	3.29	37.55	3.29	36.80	3.25	35.92	3.25
75	65	40.37	3.40	39.15	3.37	38.75	3.37	38.37	3.33	38.07	3.33	37.31	3.30	36.42	3.30

DB: Dry Bulb Temperature (°F) WB: Wet Bulb Temperature (°F) TC: Total Capacity (kBtu/h)

PI: Power Input (kW) (includes compressor, indoor fan motor and outdoor fan motor)

1. All capacities are net, evaporator fan motor heat is deducted.

2. Direct interpolation is permissible. ⊙ Do not extrapolate.

Capacity as rated: 0 ft. above sea level with 24.6 ft. of refrigerant piping. 0 ft. level difference between outdoor and indoor units.

Heating capacity rating obtained with air entering the indoor unit at 70°F dry bulb (DB) and 60°F wet bulb (WB), and outdoor ambient conditions of 47°F dry bulb (DB) and 43°F wet bulb (WB).

PERFORMANCE DATA

Maximum Heating Capacity

LS243HLV3, LS303HLV3

Maximum Heating Capacity Table for LS243HLV3 (LSU243HLV3 + LSN243HLV3)

Table 20: LSN243HLV3 / LSU243HLV3 Maximum Heating Capacities.

Outdoor Air Temp.		Indoor Air Temperature (°F DB)													
°F DB	°F WB	60		64		68		70		72		75		86	
		TC	PI	TC	PI	TC	PI	TC	PI	TC	PI	TC	PI	TC	PI
-3	-4	21.44	2.87	21.32	2.87	21.22	2.88	21.17	2.88	21.02	2.92	20.69	2.97	19.70	3.17
0	-1	22.66	2.90	22.48	2.92	22.34	2.94	22.26	2.95	22.09	2.98	21.72	3.04	20.62	3.24
1	0	23.16	2.90	22.96	2.93	22.81	2.96	22.71	2.98	22.54	3.00	22.13	3.04	20.90	3.18
6	5	25.71	3.00	25.45	3.04	25.23	3.07	23.70	3.10	23.75	3.07	24.29	3.04	21.68	2.92
10	9	27.05	3.03	26.75	3.07	26.51	3.11	25.54	3.13	26.04	3.10	25.28	3.06	22.07	2.91
16	14	28.30	3.06	27.97	3.10	27.70	3.14	26.72	3.16	27.10	3.12	26.07	3.06	22.98	2.84
17	15	28.62	3.05	28.29	3.10	28.01	3.15	27.03	3.17	27.37	3.12	26.28	3.05	23.00	2.79
19	17	28.97	3.08	28.63	3.11	28.35	3.14	27.36	3.16	27.65	3.10	26.44	3.00	22.80	2.65
24	23	30.44	3.15	30.08	3.16	29.79	3.17	29.07	3.17	28.90	3.10	27.28	2.99	22.42	2.59
32	30	32.78	3.17	32.40	3.18	32.08	3.19	31.36	3.19	30.94	3.10	28.77	2.96	22.23	2.45
41	38	35.41	3.07	35.01	3.13	34.67	3.19	33.65	3.21	33.33	3.09	30.74	2.90	22.95	2.19
43	40	36.00	3.07	35.59	3.13	35.25	3.19	34.50	3.22	33.84	3.08	31.08	2.88	22.83	2.12
47	43	37.19	3.00	36.76	3.09	36.40	3.19	36.20	3.24	34.87	3.09	31.87	2.85	22.86	2.00
53	50	38.16	3.05	37.68	3.14	37.30	3.23	37.08	3.28	35.62	3.10	32.33	2.84	22.46	1.85
59	53	38.64	2.99	38.61	3.10	38.58	3.21	38.56	3.27	36.97	3.09	33.40	2.83	22.68	1.87
64	57	38.95	2.92	38.37	2.97	37.90	3.01	37.64	3.04	36.12	2.88	32.70	2.66	22.45	1.82
70	61	39.08	2.79	38.40	2.79	37.85	2.78	37.54	2.78	36.04	2.64	32.66	2.44	22.54	1.68
75	65	38.98	2.55	38.20	2.62	37.55	2.69	37.19	2.72	35.66	2.58	32.22	2.36	21.90	1.56

Performance Data

Maximum Heating Capacity Table for LS303HLV3 (LSU303HLV3 + LSN303HLV3)

Table 21: LSN303HLV3 / LSU303HLV3 Maximum Heating Capacities.

Outdoor Air Temp.		Indoor Air Temperature (°F DB)													
°F DB	°F WB	60		64		68		70		72		75		86	
		TC	PI	TC	PI	TC	PI	TC	PI	TC	PI	TC	PI	TC	PI
-3	-4	24.71	3.61	24.57	3.62	24.45	3.63	24.39	3.63	24.22	3.68	23.84	3.74	22.70	3.99
0	-1	26.11	3.65	25.90	3.67	25.74	3.70	25.65	3.71	25.46	3.76	25.03	3.83	23.76	4.09
1	0	26.68	3.69	26.46	3.72	26.28	3.75	26.18	3.76	25.97	3.79	25.50	3.83	24.08	3.99
6	5	29.62	3.79	29.32	3.84	29.08	3.89	28.08	3.90	28.65	3.88	27.99	3.84	24.99	3.69
10	9	31.18	3.81	30.83	3.86	30.55	3.92	30.39	3.94	30.01	3.90	29.14	3.85	25.44	3.66
16	14	32.62	3.84	32.24	3.89	31.93	3.94	31.75	3.96	31.23	3.91	30.04	3.83	26.49	3.56
17	15	32.98	3.87	32.60	3.93	32.28	3.98	32.11	4.00	31.55	3.92	30.29	3.81	26.51	3.40
19	17	33.39	3.88	32.99	3.93	32.67	3.97	32.50	3.99	31.87	3.90	30.47	3.78	26.28	3.35
24	23	34.56	4.01	34.15	4.02	33.82	4.03	33.63	4.04	32.82	3.94	30.98	3.80	25.45	3.30
32	30	36.43	4.07	36.00	4.09	35.66	4.10	35.47	4.10	34.39	3.97	31.97	3.80	24.71	3.15
41	38	38.53	4.04	38.09	4.12	37.73	4.20	37.52	4.23	36.27	4.05	33.44	3.80	24.97	2.89
43	40	39.01	3.93	38.56	4.01	38.19	4.09	37.98	4.12	36.66	3.93	33.68	3.67	24.73	2.72
47	43	39.96	4.04	39.49	4.17	39.11	4.31	38.90	4.37	37.46	4.14	34.24	3.83	24.56	2.70
53	50	41.00	4.11	40.49	4.24	40.07	4.36	39.84	4.42	38.27	4.16	34.74	3.81	24.13	2.50
59	53	41.52	4.03	41.48	4.18	41.45	4.34	41.43	4.41	39.73	4.15	35.89	3.80	24.37	2.52
64	57	41.85	3.94	41.23	4.00	40.72	4.07	40.44	4.09	38.81	3.87	35.14	3.57	24.12	2.45
70	61	41.99	3.77	41.26	3.76	40.67	3.75	40.33	3.75	38.72	3.55	35.10	3.27	24.21	2.27
75	65	41.89	3.44	41.04	3.53	40.35	3.63	39.96	3.67	38.32	3.46	34.62	3.17	23.53	2.11

DB: Dry Bulb Temperature (°F) WB: Wet Bulb Temperature (°F) TC: Total Capacity (kBtu/h)

PI: Power Input (kW) (includes compressor, indoor fan motor and outdoor fan motor)

1. All capacities are net, evaporator fan motor heat is deducted.

2. Direct interpolation is permissible. ⊖ Do not extrapolate.

Capacity as rated: 0 ft. above sea level with 24.6 ft. of refrigerant piping. 0 ft. level difference between outdoor and indoor units.

Heating capacity rating obtained with air entering the indoor unit at 70°F dry bulb (DB) and 60°F wet bulb (WB), and outdoor ambient conditions of 47°F dry bulb (DB) and 43°F wet bulb (WB).



PERFORMANCE DATA

Maximum Heating Capacity

LS363HLV3

Maximum Heating Capacity Table for LS363HLV3 (LSU363HLV3 + LSN363HLV3)

Table 22: LSN363HLV3 / LSU363HLV3 Maximum Heating Capacities.

Outdoor Air Temp.		Indoor Air Temperature (°F DB)													
°F DB	°F WB	60		64		68		70		72		75		86	
		TC	PI	TC	PI	TC	PI	TC	PI	TC	PI	TC	PI	TC	PI
-3	-4	27.18	4.47	27.03	4.48	26.90	4.49	26.82	4.49	26.64	4.55	26.22	4.63	24.97	4.93
0	-1	28.72	4.52	28.50	4.55	28.32	4.58	28.21	4.59	28.01	4.66	27.54	4.74	26.13	5.06
1	0	29.35	4.56	29.11	4.60	28.91	4.64	28.80	4.65	28.57	4.69	28.05	4.74	26.49	4.93
6	5	32.59	4.69	32.26	4.75	31.98	4.81	30.89	4.84	31.51	4.80	30.79	4.75	27.49	4.57
10	9	34.30	4.72	33.92	4.78	33.60	4.85	33.43	4.88	33.01	4.83	32.05	4.77	27.98	4.53
16	14	35.88	4.75	35.46	4.81	35.12	4.88	34.93	4.91	34.35	4.84	33.05	4.75	29.14	4.41
17	15	36.28	4.79	35.86	4.86	35.51	4.93	35.32	4.96	34.70	4.85	33.32	4.72	29.16	4.21
19	17	36.72	4.81	36.29	4.86	35.94	4.91	35.74	4.93	35.06	4.83	33.52	4.68	28.91	4.14
24	23	37.30	4.84	36.86	4.86	36.50	4.87	36.30	4.88	35.42	4.75	33.43	4.59	27.47	3.98
32	30	38.22	4.69	37.77	4.70	37.41	4.71	37.21	4.72	36.08	4.57	33.54	4.37	25.92	3.63
41	38	39.25	4.38	38.80	4.46	38.43	4.54	38.22	4.58	36.94	4.38	34.06	4.11	25.43	3.13
43	40	39.48	4.19	39.03	4.27	38.65	4.35	38.45	4.39	37.11	4.19	34.09	3.91	25.03	2.89
47	43	39.96	4.04	39.49	4.17	39.11	4.31	38.90	4.37	37.46	4.14	34.24	3.83	24.56	2.70
53	50	41.00	4.11	40.49	4.24	40.07	4.36	39.84	4.42	38.27	4.16	34.74	3.81	24.13	2.50
59	53	41.52	4.03	41.48	4.18	41.45	4.34	41.43	4.41	39.73	4.15	35.89	3.80	24.37	2.52
64	57	41.85	3.94	41.23	4.00	40.72	4.07	40.44	4.09	38.81	3.87	35.14	3.57	24.12	2.45
70	61	41.99	3.77	41.26	3.76	40.67	3.75	40.33	3.75	38.72	3.55	35.10	3.27	24.21	2.27
75	65	41.89	3.44	41.04	3.53	40.35	3.63	39.96	3.67	38.32	3.46	34.62	3.17	23.53	2.11

DB: Dry Bulb Temperature (°F) WB: Wet Bulb Temperature (°F) TC: Total Capacity (kBtu/h)

PI: Power Input (kW) (includes compressor, indoor fan motor and outdoor fan motor)

1. All capacities are net, evaporator fan motor heat is deducted.
2. Direct interpolation is permissible. ⚠ Do not extrapolate.

Capacity as rated: 0 ft. above sea level with 24.6 ft. of refrigerant piping. 0 ft. level difference between outdoor and indoor units.

Heating capacity rating obtained with air entering the indoor unit at 70°F dry bulb (DB) and 60°F wet bulb (WB), and outdoor ambient conditions of 47°F dry bulb (DB) and 43°F wet bulb (WB).

EQUIPMENT SELECTION PROCEDURE

Correction Factors

Cooling / Heating Correction Factors

For Single Zone Extended Piping Wall Mounted systems, calculate the equivalent length of the liquid line from the outdoor unit to the indoor unit. Also, determine the elevation difference of the indoor unit above or below the outdoor unit. Find the corresponding cooling or heating capacity correction factors as shown below. Multiply the correction factors by the cooling or heating capacity obtained from the capacity tables using design conditions. The result is the NET cooling or heating capacity.

Cooling and Heating Capacity Coefficient Factors.

Table 23: Extended Piping Wall Mounted Cooling and Heating Capacity Coefficient Factors.

	Model No.	Operation Mode	Piping Length (ft.)										
			16.4	24.6	32.8	49.2	65.6	82	98.4	114.8	131.2	147.6	164
Rate of Capacity Change (%)	LS243HLV3	Cooling	100	100	99.6	98.7	97.8	96.9	96.0	95.1	94.3	93.4	92.5
		Heating	100	100	99.8	99.3	98.9	98.4	98.0	97.5	97.1	96.6	96.2
	LS303HLV3	Cooling	100	100	99.6	98.7	97.8	96.9	96.0	95.1	94.3	93.4	92.5
		Heating	100	100	99.8	99.3	98.9	98.4	98.0	97.5	97.1	96.6	96.2
	LS363HLV3	Cooling	100	100	99.6	98.7	97.8	96.9	96.0	95.1	94.3	93.4	92.5
		Heating	100	100	99.8	99.3	98.9	98.4	98.0	97.5	97.1	96.6	96.2

Equivalent Piping Length for Piping Components

Table 24: Equivalent Piping Length for Elbows.

Component	Size (Inches).														
Elbow (ft.)	1/4	3/8	1/2	5/8	3/4	7/8	1	1-1/8	1-1/4	1-3/8	1-1/2	1-5/8	1-3/4	2-1/8	
	0.5	0.6	0.7	0.8	1.2	1.3	1.5	1.6	1.8	2.0	2.1	2.3	2.5	2.8	

Altitude Correction Factor

The impact of air density must be considered on systems installed at a significant altitude above sea level, therefore, locally accepted altitude correction factors using ASHRAE guidelines must be applied.

Defrost Correction Factor for Heating Operation

The outdoor unit heating capacity may need to be adjusted for frost accumulation on air-cooled systems. If design day conditions are below the dewpoint of the surrounding air, frost may not be a problem and no correction factor is needed. In certain weather conditions, however, frost may form and accumulate on the air-cooled outdoor unit coil and impact the coils ability to transfer heat. If significant frost accumulates on the outdoor unit coil, a defrost algorithm will start automatically. The timing between defrost periods is determined by the system's ability to achieve a target head pressure value.

Capacity and AHRI ratings tables do not factor in capacity reduction when frost has accumulated on the condenser coil, nor during defrost operation.

Integrated heating capacity values can be obtained using the formula:

$$A = B \times C$$

Where:

A = Integrated Heating Capacity.

B = Value found in the Capacity Table.

C = Correction Factor for Frost Accumulation Factor (from table at right).

Table 25: Outdoor Unit Frost Accumulation Factor (Heating).¹

Entering DB (°F)	19.4	23.0	26.6	32.0	37.4	41.0	44.6
Derate Factor	0.98	0.95	0.93	0.86	0.93	0.96	1.0

¹At 85% outdoor air relative humidity.

The frost accumulation factor does not account for effects of snow accumulation restricting airflow through the outdoor unit coil.

Note:

There will be a temporary reduction in capacity when frost / ice accumulates on the outside surface of the outdoor unit heat exchanger. The level of capacity reduction depends on a number of factors, for example, outdoor temperature (°F DB), relative humidity (RH), and the amount of frost present.



EQUIPMENT SELECTION PROCEDURE

Correction Factors

Check the Indoor and Outdoor Unit Selection(s)

Compare the corrected cooling and heating capacities to the load calculations. Is each capacity sufficient for the zone it serves?

For the indoor unit, the corrected capacity must be at least equal to the total of the cooling design load (plus ventilation load, if applicable) for the space served by the indoor unit. For the indoor unit, the corrected capacity also must be at least equal to the total of the heating design load (plus ventilation load, if applicable) for the space(s) and / or thermal zone served by the indoor unit.

The outdoor unit selected must be large enough to offset the total cooling load for the space it serves (account for ventilation air cooling load if the ventilation air has not been pretreated to room neutral conditions). The outdoor unit must also be large enough to offset the total heating load for the space it serves.

If the corrected heating capacity ratio exceeds 100%, reselect the equipment, or change the system design by moving some of the load to another system.

System Sizing Check Formulas

1. Outdoor Unit Rated Capacity.

$Q_{\text{odu(rated)}}$ (From capacity tables).

2. Outdoor Unit Capacity at T_i , T_o Temperature.

$Q_{\text{odu}(T_i, T_o)}$ (From capacity tables).

3. Outdoor Unit Capacity Coefficient Factor.

$F_{(T_i, T_o)} = Q_{\text{odu}(T_i, T_o)} / Q_{\text{odu(rated)}}$

4. Piping Correction Factor (From Capacity Coefficient Factor Tables).

$F_{(\text{length})}$ for each piping length

5. Individual Indoor Unit Combination Capacity.

$Q_{\text{idu (combi)}} = Q_{\text{odu(rated)}} \times Q_{\text{idu(rated)}} / Q_{\text{idu(rated-total)}}$

6. Individual Indoor Unit Actual Capacity.

$Q_{\text{idu (actual)}} = Q_{\text{odu(combi)}} \times F_{(T_i, T_o)} \times F_{(\text{length, altitude})}$

Conclusions and Recommendations

- Understand the design safety factors.
- Reference load calculations for actual cooling and heating capacities (applies in 99% of applications – consider total load when latent load is greater than 30%).
- Verify that the sensible load of the zone is satisfied.
- Use caution when sizing to meet listed capacity specifications for the scheduled manufacturer's equipment.

If further system design assistance is needed, or you have a unique application you would like to discuss, contact your LG sales rep.

APPLICATION GUIDELINES

Placement Considerations on page 46

Installing Outdoor Units Indoors on page 51

Refrigerant Piping Design on page 54

PLACEMENT CONSIDERATIONS

Indoor Unit

Selecting the Best Location for the Indoor Unit

Note:

Follow required best practices when choosing an indoor location for the single zone indoor unit.

Do's

- Minimum clearance of indoor unit from the top of the unit to the ceiling must be greater than 8 inches.
- Clearance gap between any wall or enclosure and the left or right side of the unit must be greater than 4 inches. Ensure there is sufficient maintenance space.
- Unit must be at least 6-1/2 feet from the floor for adequate clearance.
- Place the unit where drainage can be obtained easily. Condensation drain must be conveniently routed away from the unit.
- Locate the indoor unit in a location where it can be easily connected to the outdoor unit within allowable limits.
- Install unit on a strong, hard wall. Use a metal detector to locate studs in the walls. Anchor unit following stud location to prevent damage to the wall.

Do Not's

- Do not install the unit near a heat or steam source, or where considerable amounts of oil, iron powder, or flour are used. (These materials will generate condensate, cause a reduction in heat exchanger efficiency, or the drain to malfunction. If this is a potential problem, install a ventilation fan large enough to vent out these materials.)
- Ensure there are no obstacles to air circulation around the unit; keep proper distances from ceilings, doorways, floor, walls, etc.
- Do not install in an area where operation sound will disturb occupants--place the unit where noise prevention is taken into consideration.
- Do not install near doorway.
- Avoid installing the unit near high-frequency generators.

WARNING

The unit must not be installed where sulfuric acid and flammable or corrosive gases are generated, vented into, or stored. There is risk of fire, explosion, and physical injury or death.

The unit will be damaged, will malfunction, and / or will not operate as designed if installed in any of the conditions listed.

Note:

- Indoor units (IDUs) must not be placed in an environment where the IDUs will be exposed to harmful volatile organic compounds (VOCs) or in environments where there is improper air make up or supply or inadequate ventilation. If there are concerns about VOCs in the environment where the IDUs are installed, proper air make up or supply and/ or adequate ventilation must be provided. Additionally, in buildings where IDUs will be exposed to VOCs consider a factory-applied epoxy coating to the fan coils for each IDU.
- If the unit is installed near a body of water, the installation parts are at risk of corroding. Appropriate anti-corrosion methods must be taken for the unit and all installation parts.

Installing in an Area Exposed to Unconditioned Air

In some installation applications, areas (floors, walls) in some rooms will be exposed to unconditioned air (room will be above or next to an unheated garage or storeroom). To countermeasure:

- Verify that carpet is or will be installed (carpet will increase the temperature by three [3] degrees).
- Add insulation between the floor joists.
- Install radiant heat or another type of heating system to the floor.

Figure 25: Extended Piping Indoor Unit Clearance Requirements.

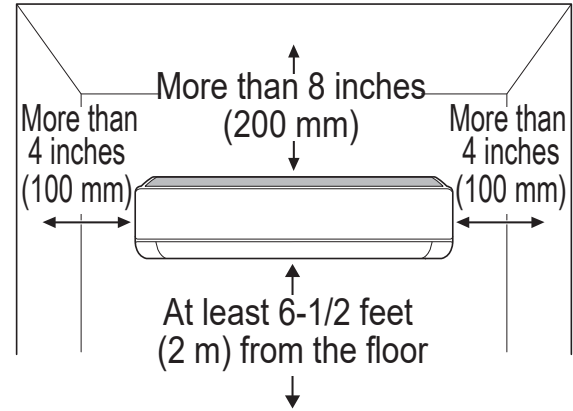
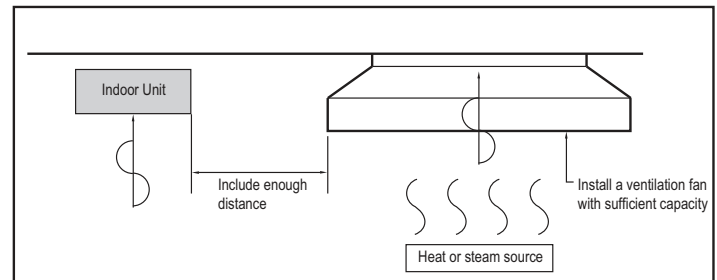

Figure 26: Installing Near a Heat or Steam Source.





PLACEMENT CONSIDERATIONS

Outdoor Unit

Selecting the Best Location for the Outdoor Unit

⚠ DANGER

-  Do not install the unit in an area where combustible gas will generate, flow, stagnate, or leak. These conditions can cause a fire, resulting in bodily injury or death.
-  Do not install the unit in a location where acidic solution and spray (sulfur) are often used as it can cause bodily injury or death.
-  Do not use the unit in environments where oil, steam, or sulfuric gas are present as it can cause bodily injury or death.

⚠ CAUTION

When deciding on a location to place the outdoor unit, be sure to choose an area where run-off from defrost will not accumulate and freeze on sidewalks or driveways, which will create unsafe conditions. Properly install and insulate any drain hoses to prevent the hose from freezing, cracking, leaking, and causing unsafe conditions from frozen condensate.

⚠ WARNING

Install a fence to prevent vermin from crawling into the unit or unauthorized individuals from accessing it. Vermin and unauthorized individuals will cause a fire, electric shock, physical injury or death. Follow the placement guidelines set forth in "Clearance Requirements".

Note:

Install a fence to prevent vermin from crawling into the unit or unauthorized individuals from accessing it. Vermin and unauthorized individuals will damage the unit. Follow the placement guidelines set forth in "Clearance Requirements".

Select a location for installing the outdoor unit that will meet the following conditions:

- A location that allows for optimum air flow and is easily accessible for inspection, maintenance, and service.
- Where piping between the outdoor unit and indoor unit is within allowable limits.
- Include space for drainage to ensure condensate flows properly out of the unit when it is in heating mode.  Avoid placing the outdoor unit in a low-lying area where water could accumulate.
- If the outdoor unit is installed in a highly humid environment (near an ocean, lake, etc.), ensure that the site is well-ventilated and has a lot of natural light (Example: Install on a rooftop).

Do Not's

- Where it will be subjected to direct thermal radiation from other heat sources, or an area that would expose the outdoor unit to heat or steam like discharge from boiler stacks, chimneys, steam relief ports, other air conditioning units, kitchen vents, plumbing vents, and other sources of extreme temperatures.
- Where high-frequency electrical noise / electromagnetic waves will affect operation.
- Where operating sound from the unit will disturb inhabitants of surrounding buildings.
- Where the unit will be exposed to direct, strong winds.
- Where the discharge of one outdoor unit will blow into the inlet side of an adjacent unit (when installing multiple outdoor units).

Outdoor Unit Condensate Drain Piping

Outdoor unit requires condensate drain piping. Condensate drain pipe is constructed with materials approved by local code. See page 50 for information in reference to outdoor unit placement.

Planning for Snow and Ice

To ensure the outdoor unit operates properly, certain measures are required in locations where there is a possibility of heavy snowfall or severe windchill or cold:

1. Prepare for severe winter wind chills and heavy snowfall, even in areas of the country where these are unusual phenomena.
2. Position the outdoor unit so that its airflow fans are not buried by direct, heavy snowfall. If snow piles up and blocks the airflow, the system will malfunction.
3. Remove any snow that has accumulated four (4) inches or more on the top of the outdoor unit.
4. In climates that will experience significant snow buildup, mount the outdoor unit on a raised, field-provided platform or stand. The raised support platform must be high enough to allow the unit to remain above possible snow drifts, and must be higher than the maximum anticipated snowfall for the location.
5. Design the mounting base to prevent snow accumulation on the platform in front or back of the unit frame.
6. Provide a field fabricated snow protection hood to keep snow and ice and/or drifting snow from accumulating on the coil surfaces.
7. To prevent snow and heavy rain from entering the outdoor unit, install the condenser air inlets and outlets facing away from direct winds.
8. Consider tie-down requirements in case of high winds or where required by local codes.



PLACEMENT CONSIDERATIONS

Outdoor Unit

Planning for Snow and Ice, continued.

⚠ CAUTION

When deciding on a location to place the outdoor unit, be sure to choose an area where run-off from defrost will not accumulate and freeze on sidewalks or driveways, which will create unsafe conditions. Properly install and insulate any drain hoses to prevent the hose from freezing, cracking, leaking, and causing unsafe conditions from frozen condensate.

Underground Refrigerant Piping

Refrigerant pipe installed underground must be routed inside a vapor tight protective sleeve to prevent insulation deterioration and water infiltration. Refrigerant pipe installed inside underground casing must be continuous without any joints. Underground refrigerant pipe must be located at a level **below the frost line**.

Table 26: Utility Conduit Sizes (Inches).

Liquid Pipe ¹	Vapor Pipe ¹			
	3/8 (2.0 ^{2,5})	1/2 (2.0 ^{2,5})	5/8 (2-1/8 ^{2,5})	3/4 (2-1/4 ^{2,5})
1/4 (1.0) ³	4	4	4	4
3/8 (1-1/8) ³	4	4	4	5
1/2 (1-1/2) ⁴	5	5	5	5
5/8 (1-5/8) ⁴	5	5	5	5
3/4 (1-3/4) ⁴	5	5	5	5

¹OD pipe diameter in inches; Values in parenthesis () indicate OD of pipe with insulation jacket.
²Diameter of pipe with insulation. Thickness of pipe insulation is typical. Actual required thickness will vary based on surrounding ambient conditions and must be calculated and specified by the design engineer.
³Insulation thickness (value in parenthesis) = 3/8 inch.
⁴Insulation thickness (value in parenthesis) = 1 inch.
⁵Insulation thickness (value in parenthesis) = 3/4 inch.

Tie-Downs and Lightning Protection

Tie-Downs

- The strength of the roof must be checked before installing the outdoor units.
- If the installation site is prone to high winds or earthquakes, when installing on the wall or roof, securely anchor the mounting base using a field-provided tie-down configuration approved by a local professional engineer.
- The overall tie-down configuration must be approved by a local professional engineer.

Note:

Always refer to local code when using a wind restraint system.

Lightning Protection

- To protect the outdoor unit from lightning, it must be placed within the specified lightning safety zone.

Table 28: Safety Zone Specifications.

Building Height (feet)	66	98	148	197
Protection Angle (°)	55	45	35	25

- Power cable and communication cable must be installed five (5) feet away from lightning rod.
- A high-resistance ground system must be included to protect against induced lightning or indirect strike.

Note:

If the building does not include lightning protection, the outdoor unit will be damaged from a lightning strike. Inform the customer of this possibility in advance.

Figure 27: Typical Arrangement of Single Zone Refrigerant Pipe and Cable(s) in a Utility Conduit.

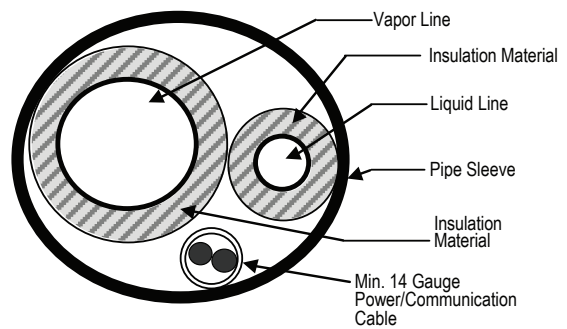
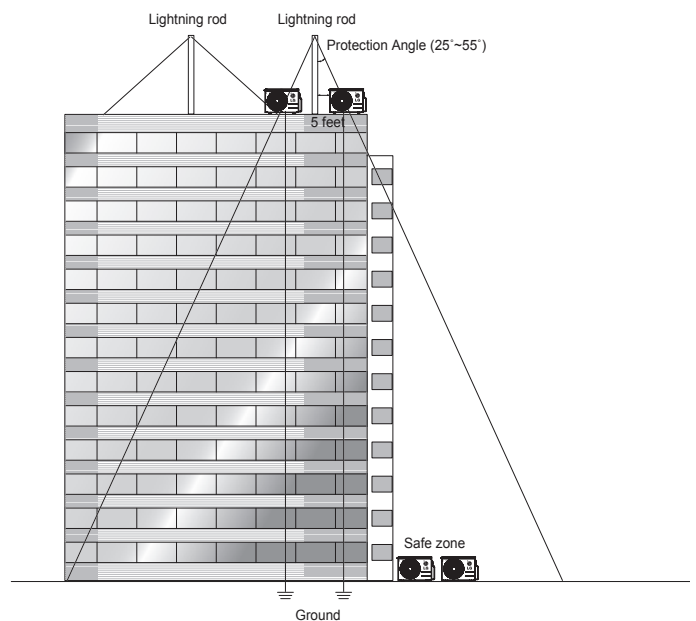

Table 27: Outdoor Unit Refrigerant Pipe Connections.

Model	Liquid Conn. (inches)	Vapor Conn. (inches)
LS243HLV3, LS303HLV3, LS363HLV3	3/8 Flare	5/8 Flare

Figure 28: Lightning Protection Diagram.



PLACEMENT CONSIDERATIONS

Outdoor Unit

Oceanside Applications

Use of a Windbreak to Shield from Sea Wind

Note:

Ocean winds will cause corrosion, particularly on the condenser and evaporator fins, which, in turn could cause product malfunction or inefficient performance.

- ⚠️ Avoid installing the outdoor unit where it would be directly exposed to ocean winds.
- Install the outdoor unit on the side of the building opposite from direct ocean winds.
- Select a location with good drainage.
- Periodically clean dust or salt particles off of the heat exchanger with water.
- If the outdoor unit must be placed in a location where it would be subjected to direct ocean winds, install a concrete windbreak strong enough to block any winds.
- Windbreak must be more than 150% of the outdoor unit's height. There must be 2 to 3-1/2 inches of clearance between the outdoor unit and the windbreaker for purposes of air flow.

Use of a Building to Shield from Sea Wind

If a windbreak is not possible, a building or larger structure must be used to shield the outdoor unit from direct exposure to the sea wind. The unit must be placed on the side of the building directly opposite to the direction of the wind as shown in the figure at right.

Figure 29: Oceanside Placement Using Windbreak.

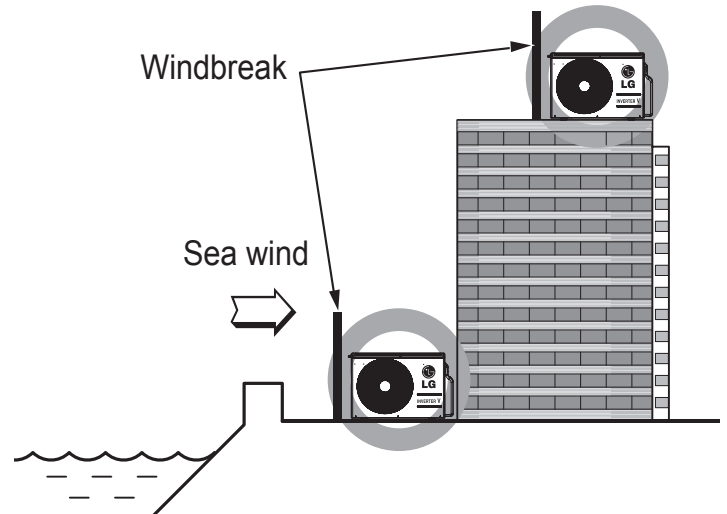

Note:

Additional anti-corrosion treatment will need to be applied to the outdoor unit at oceanside locations.

Figure 30: Placement Using Building as Shield.

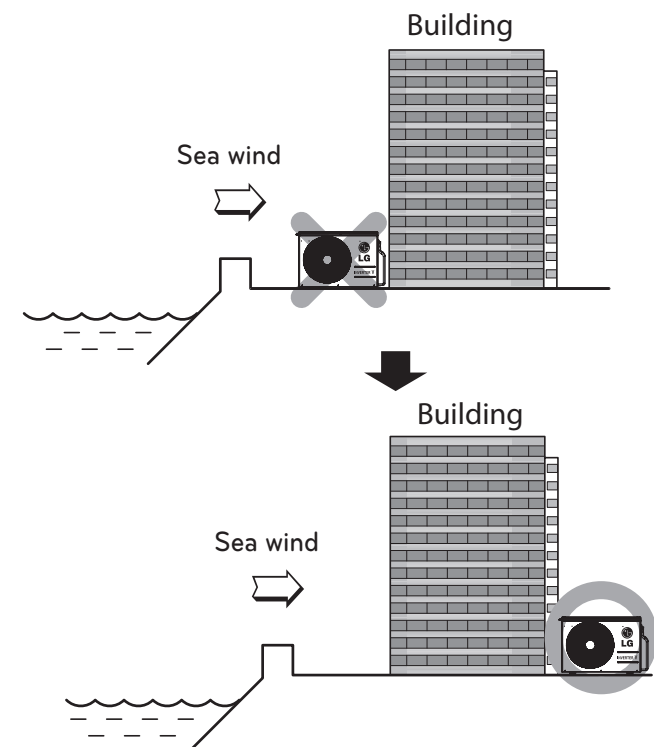

PLACEMENT CONSIDERATIONS

Outdoor Unit

Minimum Clearance Requirements for Single Zone Extended Piping Systems

Proper clearance for the outdoor unit coil is critical for proper unit operation. When installing the outdoor unit, consider service, inlet and outlet and minimum allowable space requirements as illustrated in the diagrams below.

Specific clearance requirements in the diagram below are for Single Zone Extended Piping Wall Mounted systems. Figure 31 shows the overall minimum clearances that must be observed for safe operation and adequate airflow around the outdoor unit.

When placing the outdoor unit under an overhang, awning, sunroof or other “roof-like structure”, observe the clearance requirements (as shown in Cases 1 and 2 in Figure 31) for height in relation to the unit. This clearance ensures that heat radiation from the condenser is not restricted around the unit.

Adhere to all clearance requirements if installing the unit on a roof. Be sure to level the unit and ensure that the unit is adequately anchored. Consult local codes for rooftop mounting requirements.

In order to have successful service access to the outdoor unit, see Figure 31 for minimum spacing. When installing multiple outdoor units, see Cases 4 and 5 in Figure 31 for correct spacing requirements.

Note:

If the outdoor unit is installed between standard and minimum clearances, capacity decreases approximately 10%.

Figure 31: Single Zone Extended Piping Outdoor Unit Service Access and Allowable Clearances Diagram.

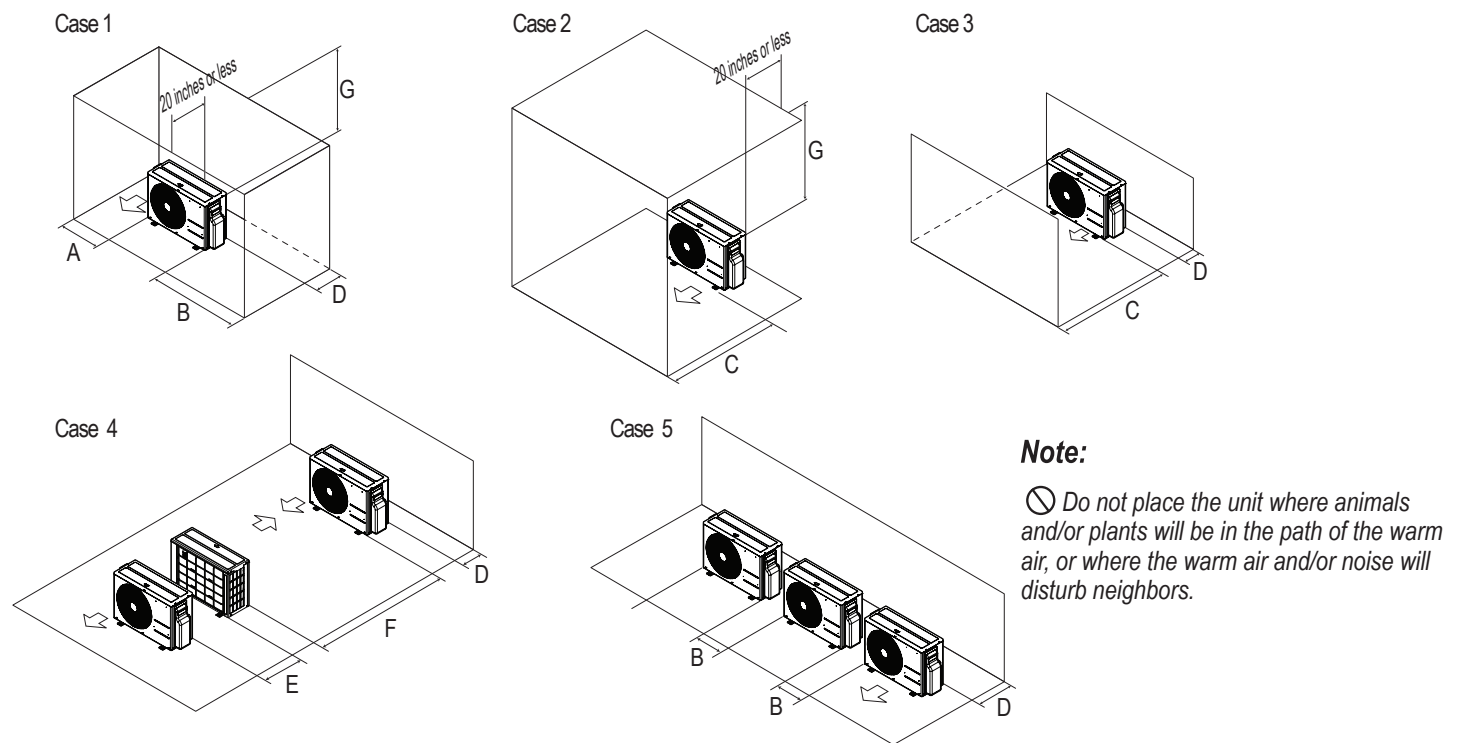

Note:

⊘ Do not place the unit where animals and/or plants will be in the path of the warm air, or where the warm air and/or noise will disturb neighbors.

Table 29: Single Zone Extended Piping Outdoor Unit Service Access and Allowable Clearances Diagram Legend.

Unit: Inch		A	B	C	D	E	F	G
Case 1	Standard	12	24	-	12	-	-	-
	Minimum	4	10	-	4	-	-	40
Case 2	Standard	-	-	20	-	-	-	-
	Minimum	-	-	14	-	-	-	40
Case 3	Standard	-	-	20	12	-	-	-
	Minimum	-	-	14	4	-	-	-
Case 4	Standard	-	-	-	12	24	-	-
	Minimum	-	-	-	4	8	79	-
Case 5	Standard	-	24	-	12	-	-	-
	Minimum	-	10	-	4	-	-	-

PLACEMENT CONSIDERATIONS

Installing Outdoor Units Indoors

Installing Outdoor Units Indoors

Single Zone Extended Piping Wall Mounted outdoor units are engineered to be mounted outdoors and include technology designed to minimize the negative effects of winter weather's freezing rain, sleet, and snow. Some building projects, however, necessitate placing the HVAC outdoor units indoors:

- Lack of ground space.
- Lack of an appropriate outdoor location that meets system design requirements.
- When mounting on the roof is not an option due to a lack of roof space.
- Roof warranty will be voided if mechanical equipment is placed on the membrane.
- On retrofit projects, a former chiller / boiler / air handler equipment room, mechanical area, or penthouse already exists.
- To curtail the potential need for redundant zone heating devices such as wall-fin radiators or duct heaters.
- In extremely cold environments where there is a significant amount of run-time at temperatures well below freezing outside the outdoor unit ambient air temperature range published in this engineering manual.

Benefits of Installing Outdoor Units Indoors

- Shelters the outdoor unit from direct exposure to prevailing winds that decrease the heating capability of the outdoor unit.
- Protects equipment from freezing precipitation and / or potential ice build-up that could hinder unit operation.
- Maintains coil heat transfer efficiency by reducing the number of and shortening the cycle time for defrost operation.
- Easier maintenance and servicing during inclement weather.
- When mounted in a fully enclosed space, limiting the ambient air temperature will allow the Single Zone Extended Piping Wall Mounted system designer to eliminate oversizing.
- The outdoor unit to compensate for loss of capacity at low ambient temperatures.
- Will also curtail the need to provide inefficient redundant zone heating devices such as wall-fin radiators and second-stage ancillary heating devices.

Design Considerations Include:

- Enclosure types and elements such as louvers (see next page), rain hoods, dampers and controls, heating methods and sizing of heating devices.
- Heating strategies.
- Duct design.
- Condensate handling.

General Guidelines

- Follow ASHRAE 62.1 design guidelines.
- Depending on the project / application, a roof over the outdoor units in combination with a wind break will be all that is necessary.
- Consider the potential for snow accumulation near louvers / roof openings. Outside air intakes and discharge ducts/louvers must be engineered to clear anticipated snow accumulation levels by at least one (1) foot.
- In situations where operation is anticipated at temperatures lower than the product's minimum operating temperature, ancillary heat must be provided to heat the outdoor unit coils to ensure continuous compressor operation and heating.

It will be necessary to use a field-fabricated air guide to prevent discharge air from short-cycling back to the coil inlet.

- Consider the direction of prevailing winds and opening placement. If possible, locate inlet openings upwind of discharge openings and other exhaust outlets.
- When inlet and outlet openings are placed on the same wall, minimum distance between the two openings must be approximately three (3) feet (minimum distance varies significantly with variations in outlet opening face velocity).
- If roof-mounted ventilation openings are used, strategically locate the inlet ventilation opening(s) upwind of the outlet opening(s).
- Discharge and supply ductwork must be designed to avoid weather related long periods of water entrainment and the potential for microbial growth.

PLACEMENT CONSIDERATIONS

Installing Outdoor Units Indoors

Provide a means to drain the condensate generated during heating mode and defrost cycle in addition to rainwater that infiltrates the inlet louver enclosed area.

- Install a field-provided drain pan under the outdoor units and provide a path to a nearby floor drain.
- If the ambient air temperature is expected to drop below 32°F in the enclosure, heat the bottom surface of the pan, drain line, and floor drain so that the condensate does not freeze before reaching the drain.

⚠ CAUTION

When deciding on a location to place the outdoor unit, be sure to choose an area where run-off from defrost will not accumulate and freeze on sidewalks or driveways which will create unsafe conditions.

Allow for ventilation intake and exhaust air based on maximum outdoor unit fan capacity.

- Select the size, type and orientation of architectural louvers with adequate “net free area” face velocity to ensure the total external static pressure from the outdoor unit fan does not exceed design limitations (see specification data tables).
- No obstructions must be placed in front of the louver that could hamper the free flow (throw) of air.
- Roof top openings and / or discharge and supply louvers must be equipped with screens to prevent bird and insect infiltration.

Note:

For louver recommendations, see below and on the next page.

As always, the best solution for each project balances acceptable heating performance (considering local weather conditions), capital costs, life cycle energy consumption, and limitations set forth by local building codes.

Louver Recommendations for Outdoor Unit Enclosure

1. Outdoor Unit Enclosure: Manual Door Open Type.
2. Louver Angle: No More Than 15° Horizontally.
3. Space Between Louvers: More than 4 inches (Recommend).
4. Louver Shape: Wing or Plane Type.

Note:

- Open Rate and Inlet must be taken into consideration when designing the louvered outdoor unit enclosure.
- Do not use “S” type louvers.

Note:

If the Louver Open Rate is Too Small

1. Noise can occur because of the increased air velocity passing through the louver blade.
2. Noise can occur from louver blade vibrations.
3. A drop in outdoor unit fan performance (excess static pressure can cause a drop in outdoor unit performance and heat exchanger efficiency).
4. If the louver open rate is too small or there is insufficient air flow exchange, the air conditioner might stop operating.

Figure 32: Louver Recommendations.

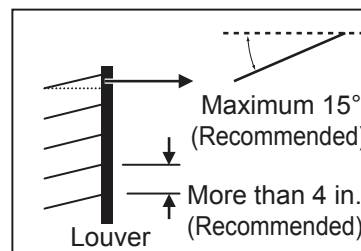
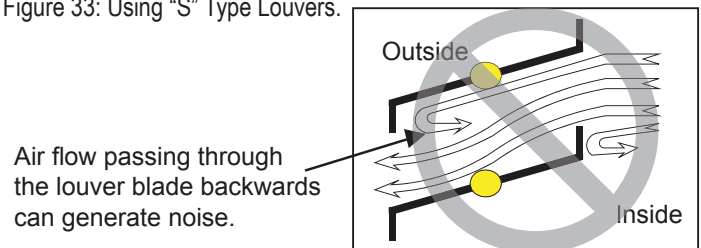

Figure 33: Using “S” Type Louvers.



PLACEMENT CONSIDERATIONS

Installing Outdoor Units Indoors

Open Rate by Louver Radian

Figure 34: Open Rate by Louver Radian Formula.

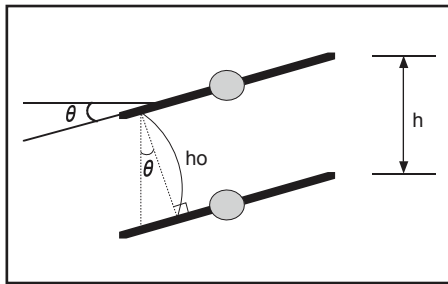

$$\theta \leq 15$$

$$h_o = h * \text{COS } \theta$$

$$\text{Total Area (A)} = H * W$$

$$\text{Number of Open Spaces (N)} = (\text{Number of Louvers} - 1)$$

$$\text{Effective Area (Af)} = h_o * W * N$$

$$\text{Louver Open Rate (n)} = A_f / A$$

$$\therefore A_f = A * n$$

Effective Cross Section Area

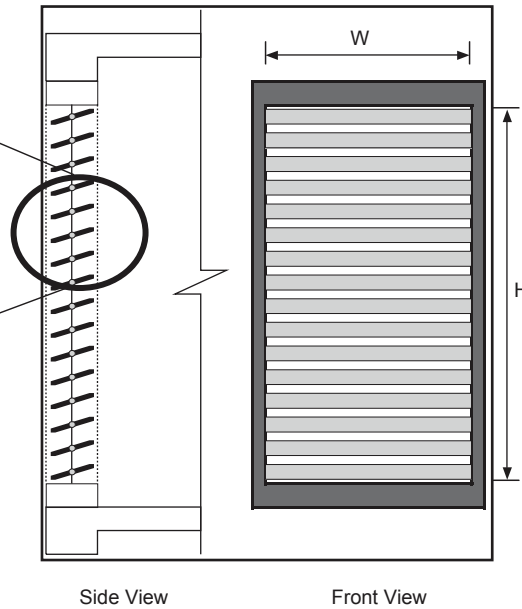

Confirming Air Flow Rate / Total Opening Rate

• Example: LSU243HLV3

- Discharge Airflow Rate: 2,119 ft.³/min.
- Velocity of Outlet Air: 16.4 ft./s
- Velocity of Inlet Air: 8.2 ft./s

• Open Rate = 80% or More

$$\text{Open Rate} = \frac{\text{Effective Face Area (Af)}}{\text{Total Face Area (A)}}$$

- Inlet airflow must match or exceed discharge airflow.
- Separate inlet airflow from discharge airflow to prevent recirculation.

Figure 35: Example of Installing Outdoor Unit Indoors.

Louver Dimensions

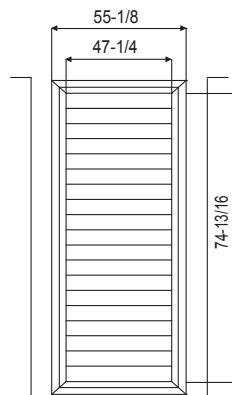

Unit: Inch

Air Guide Duct on Outdoor Unit

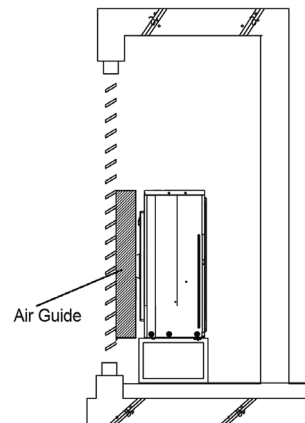

Outdoor Unit Dimensions

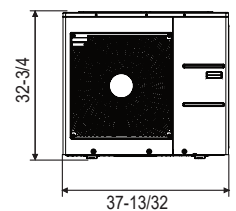

Formula

- Total Louver Dimension (Excluding Frame) (A) = 3.9 feet x 6.2 feet = 24.2 ft.²
- Area Blocked by Outdoor Unit (Discharge) (B) = 2.6 feet x 2.8 feet = 7.41 ft.²
- Inlet Louver Dimension (A - B) = 16.8 ft.²
- Equivalent Inlet Dimension (Open Rate 80%) = 16.8 ft.² x 0.8 = 13.44 ft.²
- Equivalent Inlet Airflow = 13.44 ft.² x 8.2 ft./s x 60 sec./min. = 6,612 ft.³/min.
- Equivalent Inlet Airflow / Discharge Airflow = 6,612 ft.³/min. / 2,119 ft.³/min. = 312% (Within Allowable Limits)

REFRIGERANT PIPING DESIGN

Design Guideline Summary

Device Connection Limitations

Single-zone systems consist of one outdoor unit and one indoor unit. One of the most critical elements of a single zone system is the refrigerant piping. The table below lists pipe length limits that must be followed in the design of a Single Zone Extended Piping Wall Mounted refrigerant pipe system. Refer to the figure for maximum length and elevation of piping.

Figure 36: Single Zone Extended Piping Wall Mounted System Layout.

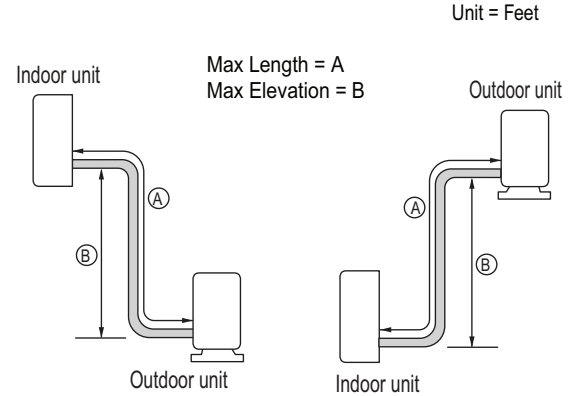

Table 30: Single Zone Extended Piping Wall Mounted Refrigerant Piping System Limitations.

Model Numbers		LS243HLV3	LS303HLV3	LS363HLV3
Pipe Sizes	Vapor	5/8 inches	5/8 inches	5/8 inches
	Liquid	3/8 inches	3/8 inches	3/8 inches
Pipe Length (ELF = Equivalent Length of pipe in Feet)	Standard Piping Length	24.6	24.6	24.6
	Piping Length with No Additional Refrigerant	24.6	24.6	24.6
	Longest Total Equivalent Piping Length	164.0	164.0	164.0
	Shortest Total Equivalent Piping Length	9.8	9.8	9.8
	Distance between fittings and indoor units or outdoor units	≥20 inches	≥20 inches	≥20 inches
Elevation (All Elevation Limitations are Measured in Actual Feet)	If outdoor unit is above indoor unit	98.4	98.4	98.4
	If outdoor unit is below indoor unit	98.4	98.4	98.4
Additional Refrigerant Needed (oz./ft)		0.38	0.38	0.38

Table 31: Single Zone Wall Mounted Extended Piping Additional Refrigerant by Piping Length (oz.).

Model Numbers		Refrigerant Piping Length (feet)											
		16.4	24.6	32.8	41	49.2	65.6	82	98.4	114.8	131.2	147.6	164.0
LS243HLV3 (LSN243HLV3 / LSU243HLV3)	Additional Refrigerant Charge (oz.)	0	0	3.1	6.2	9.3	15.6	21.8	28.0	34.3	40.5	46.7	53.0
LS303HLV3 (LSN303HLV3 / LSU303HLV3)		0	0	3.1	6.2	9.3	15.6	21.8	28.0	34.3	40.5	46.7	53.0
LS363HLV3 (LSN363HLV3 / LSU363HLV3)		0	0	3.1	6.2	9.3	15.6	21.8	28.0	34.3	40.5	46.7	53.0

Note:

- Capacity is based on standard length.
- Equivalent Pipe Length = Actual Pipe Length + Number of Bends x 0.3.
- Additional Refrigerant Charge Calculation : $X (g) = [(Refrigerant Pipe Length) - (No Charge Pipe Length)] \times (Additional Refrigerant)$.
- There is no need to add refrigerant if equivalent pipe is less than the "piping length with no additional refrigerant" in the table above.

Inverter



LG Electronics, U.S.A., Inc.
Air Conditioning Technologies
4300 North Point Parkway
Alpharetta, Georgia 30022
www.lghvac.com

EM_SZ_WallMounted_ExtendedPiping_HLV3_03_2020
Supersedes: EM_SZ_WallMounted_ExtendedPiping_HLV_11_18
EM_SZ_WallMounted_ExtendedPiping_HLV_12_16
EM-SZ-HighEfficiencyWallmount-HSV3-HV3-HLV-9-16
EM-SZ-HighEfficiencyWallmount-HSV3-HV3-HLV-6-16
DFS-EM-AH-001-US 014D10